



# International Journal of Transactional Analysis Research

Volume 7 Issue 2 July 2016

ISSN 2218-3159

<https://doi.org/10.29044/v7i2>



## Volume 7 Issue 2 July 2016

### Contents

Editorial <i>Julie Hay</i>	2
Impact of the Application of Redecision Methods in Executive Coaching Workshops on Psychological Wellbeing: a Quantitative Evaluation of Effectiveness. <i>Mark Widdowson, Peter Theuns, Mil Rosseau &amp; Rik Rosseau</i>	3
Combinations of Injunctions and Personality Types Determining Forms of Self-Destructive Behaviour in Alcohol-Dependent Clients: Findings of a Russian Observational Study <i>Dmitri I. Shustov, Olga D. Tuchina, Sergei A. Novikov &amp; Ilya A. Fedotov</i>	10
An Investigation using a Case Study Approach into the Impact on a Counselling Team in the UK of an Organisational Restructuring within a Family Support Service <i>Gillian Robinson</i>	21
The Many Faces of Transactional Analysis: A Survey Study of the Practice and Identity of Transactional Analysis Therapists in the UK <i>Siobhan Gregory</i>	29



## Editorial

### Julie Hay

I am delighted that we now have the third paper in the series about the redecision-based workshops run by Mil and Rik Rosseau as part of an executive coaching programme (see IJTAR 5: 1 for parts 1 and 2) – and they have teamed up with Peter Theuns to handle the statistics and with Mark Widdowson who has so much experience of case study research – so now we have some hard data about the impact of the training on the psychological wellbeing of the participants.

Next we have a great contrast – an investigation to identify patterns of injunctions and personality types as they relate to the self-destructive behaviours exhibited by alcohol-dependent out-patient clients in Russia.

Following this is a review of the impact on a counselling team of organisational changes made within a hospice in the UK. Although a small study, it generates some interesting ideas about the application of several TA concepts and invites us to consider whether the team are paralleling the clients in some way.

Our fourth paper is a survey of transactional analysis therapists in the UK, indicating how they view their professional identities – and particularly how they relate to the various schools of TA, and how integrative they believe themselves to be.

#### Request for help with research

IJTAR has an associated website at [www.taresearch.org](http://www.taresearch.org) where we operate a (fledgling) research exchange designed so that researchers can invite involvement in their projects. The site also contains the IJTAR Abstracts – in English, French, Italian, Spanish and German – with Russian due to follow soon thanks to a volunteer.

We have just received our first request for help – so in addition to having it on the website, I am including it in my Editorial. Please respond to the researcher if you can, and please consider whether you too might want to submit a request for involvement with your own research.

*From Emma Haynes*

*I am a transactional analysis psychotherapist studying for a PhD at The University of Salford, United Kingdom. My research is on TA psychotherapy as a suitable treatment option for perinatal psychological distress (which I define as depression, stress, and/or anxiety). I am looking for TA psychotherapists who work with women suffering from any of these three conditions who might want to become part of my research. I need a maximum of 15 women participants (clients) who have had TA psychotherapy or who are in the process of, or about to begin, who would be willing to be interviewed by me at the end of their therapy.*

*Your participation would require you to propose my research to your clients and to give the relevant paperwork to those clients who have expressed an interest in participating. Your work with your client should not change in any way. Also, your client's confidentiality is paramount, and the only person who would know that you are working with her would be me because I will perform the interview with your client. All data I collect from your client will be anonymized to ensure confidentiality. The interview is not designed to be onerous and should take around 1-1.5 hours.*

*At present, it seems that few psychotherapists see this particular client group, and there is no research at present on TA as a suitable treatment option. There is also little research, per se, about this condition, so my project will help to enhance our knowledge of the condition as well as to address the gap in TA research.*

*If you are willing to be a part of this research, please contact me: Emma Haynes, by email at [emmafhaynes@aol.com](mailto:emmafhaynes@aol.com) or by phone at (+44) 07771 518699.*



## Impact of the Application of Redecision Methods in Executive Coaching Workshops on Psychological Wellbeing: A Quantitative Evaluation of Effectiveness.

© 2016 Mark Widdowson, Peter Theuns, Mil Rosseau & Rik Rosseau.

### Abstract

Previous research has found that participants in rededication marathons experience increased personal growth and improvements in psychological well-being (McNeel, 1982; Noriega-Gayol, 1997; Widdowson & Rosseau, 2014). In this article, the authors conducted a quantitative analysis based on the use of the Ryff Scales of Psychological Wellbeing to determine whether participants (n=49) at an executive coaching rededication marathon would experience an increase in psychological well-being. The findings show statistically significant improvements in psychological well-being overall, and specifically within the sub-scales of autonomy, environmental mastery, personal growth and self-acceptance, suggesting that rededication-based workshops are effective for improving subjective psychological well-being.

### Key Words

transactional analysis, rededication, effectiveness, psychological wellbeing, executive coaching.

### Introduction

This is the third article in a series which has examined the use of rededication methods (Goulding & Goulding, 1979) as applied in an executive coaching workshop context. The first article (Rosseau, Rosseau & Widdowson, 2014) outlined the basic structure of the workshop and key theoretical concepts which guide the workshop process. The second article (Widdowson & Rosseau, 2014) was a qualitative study which explored participants' experiences of attending the workshop. The qualitative study found that participants experienced enhanced self-awareness, a greater sense of self-acceptance, increased self-esteem and self-confidence and an increased sense of well-being. Additionally, participants in the qualitative study experienced positive interpersonal changes and improvements in their leadership skills.

With the present article, we take our investigations further, by using a quantitative measure of psychological

wellbeing to examine whether the rededication-based executive coaching workshop is effective at increasing the subjective sense of psychological wellbeing amongst participants.

For many years, psychologists and other associated professionals developed a vast range of tools to assess pathology and symptoms. Since the development of the positive psychology movement (Seligman & Csikszentmihalyi, 2000), there has been a growing number of professionals who are seeking to understand and enhance psychological wellbeing (PWB), as opposed to approaches which seek to reduce symptoms and psychopathology.

Defining and measuring PWB has been problematic, with a growing consensus amongst researchers that PWB appears to be a complex and multi-dimensional construct (Diener, 2009; Dodge, Daly, Huyton & Sanders, 2012; Pollard and Lee, 2003). Furthermore, there is some debate about the extent to which PWB can be considered a stable trait, as opposed to a more fluctuating state. Headley and Wearing (1991) and Dodge et al (2012) consider that PWB can be defined as a state of equilibrium whereby an individual's personal and social resources (including personality factors and socio-economic/ demographic factors) are either stretched or replenished by life events which either deplete or enhance PWB respectively.

A number of authors support a dynamic equilibrium theory of PWB as constituting a stable sense of PWB which is supported or challenged by resources and challenges respectively (Reber, 1995; Headley and Wearing, 1992; Suh, Diener & Fujita, 1996). "In essence, stable wellbeing is when individuals have the psychological, social and physical resources they need to meet a particular psychological, social and/or physical challenge. When individuals have more challenges than resources, the see-saw dips, along with their wellbeing and vice-versa" (Dodge et al., 2012: 230).

## Ryff Scales of Psychic Wellbeing

Carol Ryff (1989) identified a series of dimensions which can be combined to give a sense of an individual's subjective experience of PWB, synthesising material from a number of literature sources regarding PWB and developing a multi-dimensional model of PWB, from which she developed the 42 item Ryff Scales of Psychological Well-being.

The six dimensions of the Ryff Questionnaire (2015) are:

- High scorers on the **Self-Acceptance Scale** are considered to have a positive attitude towards self and a general sense of acceptance of all sides of their personality - both good and bad. Low scorers would have a sense of dissatisfaction about self and dislike particular personal characteristics or traits.
- High scorers on the **Positive Relations with others** scale would have "warm, satisfying, trusting relationships with others; be concerned about the welfare of others (and would be) capable of strong empathy, affection, and intimacy" (Ryff & Keyes, 1995: 727), Low scorers would have poor or strained relationships with others, and may feel isolated or find it difficult to express feelings of warmth in relationships.
- High scorers on the **Autonomy** scale would have a clear sense of independence and self-determination and have an internal locus of evaluation (Rogers, Kirschenbaum & Henderson, 1990). Low scorers on this scale may be overly concerned with other's views or expectations and may have a tendency to defer to other's opinions.
- Those scoring highly on the **Environmental Mastery** scale are considered to have a clear sense of competence over their life and environment and experience a capacity to manage complex and multiple activities. Low scores on this scale are associated with people who have difficulty in managing the demands of day to day life, showing a low sense of control over the external world and their surroundings.
- A high score on the **Purpose in Life** scale is seen as indicative of a person who has a clear sense over their personal goals and direction in life and has a sense of personal meaning in relation to their current and past life. Those with low scores on this scale are considered to have little sense of purpose or meaning in their life and may lack clear personal goals or have little sense of personal direction.
- Finally, persons who score highly on the **Personal Growth** scale are viewed as having a sense of openness to experiences and having a feeling of continual change, growth and personal development. Individuals with a low score on this scale are considered to experience a sense of stagnation with a feeling of little improvement or growth over time and low ability to develop new attitudes or behaviours (Ryff & Keyes, 1995).

Ryff & Keyes (1995) conducted a confirmatory factor analysis study which investigated the validity of Ryff's measure using a large national probability sample (n=1108) of persons living in the United States. Their study confirmed the validity of the theoretically-based scale dimensions and supported claims that the tool can effectively measure PWB.

The measure is not without its critics. In particular, it has been critiqued for its factor validity, and there have been concerns regarding the clarity and distinctiveness of the dimensions and whether there is clear validity to the six factor structure of the measure (Abbott, Ploubidis, Huppert, Kuh, Wadsworth & Croudace 2006). One large scale validity study conducted by Abbott et al (2006) examining validity and drawing on a large sample (n=1179) of women in the UK aged between 47 and 54, suggested that the six dimensions of the Ryff scales could indeed be reduced to three scales; autonomy, positive relations and motivation/self-direction. These three scales were considered to be similar to the three-factor structure of PWB as described by Deci and Ryan (1985, 2000), who put forward the hypothesis that PWB is associated with the fulfilment of the three psychological needs of autonomy, relatedness and competence.

The study by Abbott et al (2006) indicated high correlations between the environmental mastery, purpose in life, personal growth and self-acceptance scales, which may suggest that these four dimensions may possibly be subsumed within an overarching category of general wellbeing. They also found a strong negative association between high PWB scores and a measure of psychological distress, which was clearest for the Ryff environmental mastery scale, suggesting that individuals with low scores on this scale generally feel a sense of helplessness, have a low sense of control over their environment and may associate this with some kind of global and stable internal cause. Despite their findings, Abbott et al (2006) did not reject the six-factor Ryff model, but suggested that further work to examine the factor validity of the measure is warranted.

Several other studies have examined the construct validity of the six scales proposed by Ryff, which present sometimes conflicting findings, although they largely indicate that there is some overlap between the different sub-scales. For example, a study by Springer & Hauser (2006) suggested that there was insufficient distinction between the six scales. In contrast, a large-scale study conducted in Spain and Columbia supported the six-factor model (van Dierendonck, Diaz, Rodriguez-Carvajal, Blanco & Moreno-Jiminez, 2008). Clearly there is much to be learnt about PWB, and the research tools available at present require further refinement. Nevertheless, the Ryff scale does appear to be sufficiently valid to provide an indication of subjective changes in PWB.

## Previous TA Research

The extent of previous TA research which has examined the impact of intensive workshops is rather limited. One study by McNeel (1982) examined the effects of an intensive, three-day redecision workshop (n=15) which used a measure of 'self-actualisation' (the personal orientation inventory) and a non-standardised tool (the personal growth checklist). Both measures were rated by both participants and their close associates such as partners/ family members, providing an interesting perspective on subjective and observable changes amongst participants in the workshop. The study found that participants attending the workshop did experience statistically significant personal growth on both measures. Another study based on the intensive marathon workshop was conducted by Noriega Gayol (1997). In this study, she explored the effects of attending a one-week intensive therapy marathon on self-esteem. The marathon was based on an integration of redecision therapy, self-reparenting and contracting methods. The study found statistically significant improvements in self-esteem amongst participants at the end of the workshop and at three-month follow-up.

As discussed above, our previous study (Widdowson & Rosseau, 2014) used qualitative research to explore the type and nature of any changes that participants experienced in a three-day workshop based on the redecision methods of Goulding and Goulding (1979). This indicated a number of changes, including increased self-awareness, improvements in relationships, as well as increases in self-acceptance, self-confidence and subjective wellbeing. We decided that we would examine these findings further by conducting quantitative research to see if these effects could be reproduced in a form which is measurable and therefore can be subjected to statistical analysis. In this present study, we conducted a pre-post-test study design, based on evaluating whether or not participants experienced an increase in subjective PWB, as measured by the Ryff scale of psychological wellbeing. The scale was selected because, despite some debate on the matter, as a scale it does have established validity. Furthermore, the authors considered that the different dimensions may provide greater specificity to the findings regarding the type and extent of changes amongst participants. A final, and not unimportant consideration in selecting the Ryff scales was that these are free to use and do not require a licence, which would have added cost implications to an unfunded study.

## Aims

The aim of the current study was to build on the qualitative research conducted by Widdowson & Rosseau (2014), where participants reported increases in their self-awareness, self-esteem, self-confidence, self-acceptance and subjective sense of wellbeing, and to substantiate these findings by conducting a quantitative study which investigated changes in psychological wellbeing amongst participants in an

intensive workshop based on redecision methods. As such, this present study is part of a programme of work by three of the authors (MW, MR & RR) to examine the process and outcome of redecision work in different contexts, and using a range of complementary research methods. As no single research method can provide a complete and comprehensive picture of the area of study, utilising multiple methods allows for a more detailed analysis of the subject under consideration. In this instance, the previous qualitative research gave some indication as to the nature of change experienced by participants in the redecision-based workshops, whereas the present study was designed to examine the extent of these changes, specifically those relating to improvements in subjective PWB and whether these changes would be statistically significant.

## Method

The study was conducted drawing on participants working for one organisation. The workshops were facilitated by Mil Rosseau and Rik Rosseau, who had been contracted by the organisation. The nature and structure of the workshops has previously been described in an article by Rosseau, Rosseau and Widdowson (2014). The organisation was consulted about conducting the research within their organisation and they were enthusiastic and supportive in providing their organisational consent. Prior to attending the workshop, participants were advised that three of the authors (MW, MR, RR) were conducting research on the impact of the workshop on psychological wellbeing as part of an existing programme of research, and that they would be invited to complete a questionnaire at several intervals. At the beginning of the workshops, the nature of the research was explained to participants, who were advised that participation was voluntary, and that their choice to participate or not would in no way alter their relationship with the facilitators of the workshop: they would be able to continue with the workshop even if they did not complete the questionnaires. Participants were invited to ask questions about the research at any stage. No incentives were offered for participation in the research.

As the workshops were conducted in Dutch, the Ryff (2015) questionnaire was translated into Dutch by two of the authors (MR and RR). The original English version and this initial Dutch translation were sent to Dr Peter Theuns, for checking and correction where relevant. After this, these three authors discussed and agreed on the final translation used in the study.

The Ryff questionnaire was administered on three occasions; the first was after the opening 'check in' and introduction to the workshop, the second was at the end of day three of the workshop, and the third was at the end of the fourth follow-up day. Upon each administration, participants were reminded about the study and that participation was voluntary, in order to ensure repeated informed consent. After this, copies of the questionnaire were distributed amongst the group, together with a



dated envelope. Participants were asked to simply read the brief instructions at the beginning of the questionnaire and then complete the questionnaire accordingly, if they wished to participate.

The questionnaires were anonymously administered, although each questionnaire had a unique identifier code to allow tracking of changes over the three consecutive administration points. The identifier code was self-generated by the participants, based on a combination of segments of aspects of the day of the month in which they were born and the last three digits of their post code. This would ensure that each participant had an identifier which would be known by them, and which would not personally identify them to the researchers. Although there was a theoretical possibility that more than one participant might have the same identifier code, all participants had a unique code.

Once completed, the participants placed their questionnaire in the dated envelope supplied. They then sealed the envelope and handed them to the workshop facilitators. Participants were advised that by returning the completed questionnaire, they were consenting for their data to be included in a data base and used for the purposes of this study. To allow for withdrawal from the research, it was decided that only participants who had completed and returned all three questionnaires would be included in the data analysis. This would mean that if a participant changed their mind, all of their data would be withdrawn. In the end, no participants withdrew from the study, and so data from all 49 participants could be analysed for this study.

### Data analysis

All data was sent to Dr Peter Theuns, at Vrije Universiteit Brussel, who conducted the statistical analysis of the data. The data were analysed with SPSS version 22 (IBM Corp, 2013). This included an analysis of the internal consistency of the Ryff scales (Cronbach's Alpha) and a repeated measures ANOVA to establish the significance of the evolution of the Ryff scale scores across the 3 consecutive data collection occasions. Dr Theuns was approached for the data analysis as he has no allegiance to TA and was considered to be an independent academic with a strong reputation for psychological research.

## Results

### Reliability analysis

The Cronbach's Alpha reliability analysis suggests that the internal consistency of the Ryff scales is generally good, as can be seen in Table 1. However, Item 08 ("The demands of everyday life often get me down.") shows a negative correlation with its scale Environmental Mastery. Content wise it seems that this item needs to be reverse coded in order to make it fit in the scale. With this recoding Cronbach's alpha for the Environmental Mastery scale increases from .503 to .787. So, with item

8 reverse coded all Ryff scales show a good internal consistency with Cronbach's Alpha's ranging from .719 to .832.

Scale	Items	Cronbach's Alpha (number in brackets is where item 8 is NOT reverse coded)
a. Autonomy	1, 7, 13, 19, 25, 31, 37	.749
b. Environmental mastery	2, 8, 14, 20, 26, 32, 38	.787 (.503)
c. Personal Growth	3, 9, 15, 21, 27, 33, 39	.719
d. Positive Relations	4, 10, 16, 22, 28, 34, 40	.814
e. Purpose in life	5, 11, 17, 23, 29, 35, 41	.754
f. Self-acceptance	6, 12, 18, 24, 30, 36, 42	.832

\* Underlined items are reverse coded.

\*\* The number in brackets is where item 8 is NOT reverse coded

*Table 1: Internal consistency of Ryff scales*

### Evolution of Ryff scale scores: repeated measures ANOVA

When comparing Ryff scale scores for the 3 administration points (pre, post and follow-up), an overall increase in all scale scores is observed. A repeated measures ANOVA indicates that this increment is statistically significant for all scales except Positive Relations.

Statistically significant positive change occurred on the scales of autonomy, environmental mastery, personal growth and self-acceptance at the <.001 level, and statistically significant positive change on the purpose in life scale at the .003 level. Although the trend in the data was for improvement in the positive relations scale, the results were not statistically significant.

## Discussion

This study has provided support to the findings from Widdowson & Rosseau (2014) which found that participants in the redecision-based workshop experienced increases in self-acceptance, mastery and psychological wellbeing. This is also consistent with the findings of McNeel (1982) who found that participants in a redecision marathon experienced enhanced personal growth. Clearly further research is needed to determine if such improvements in psychological wellbeing would occur in a clinical population.

Scale	Average (SD) Time 1	Average (SD) Time 2	Average (SD) Time 3	F	p
a. Autonomy	24.35 (5.278)	25.78 (5.444)	28.27 (3.872)	17.277	<.001
b. Environmental mastery	29.35 (5.399)	30.90 (5.080)	32.06 (5.133)	16.145	<.001
c. Personal Growth	29.82 (4.963)	30.78 (6.103)	32.33 (4.879)	8.871	<.001
d. Positive Relations	31.61 (6.103)	32.18 (5.985)	32.73 (5.057)	2.072	.145*
e. Purpose in life	30.43 (5.489)	31.61 (5.361)	32.51 (4.726)	6.034	.003
f. Self-acceptance	27.35 (6.369)	28.73 (5.484)	29.98 (5.471)	9.160	<.001

\* Huynh-Feldt corrected p-value corrects for violation of sphericity assumption.

*Table 2: Repeated measures ANOVA*

Despite participants in the Widdowson & Rosseau (2014) study reporting an improvement in their interpersonal functioning and relationships, this was not evidenced in the present study, where the 'positive relations' did show a small improvement of about one fifth of a standard deviation, which is not enough for statistically significant results. It is possible that the Ryff positive relations scale was not sufficiently sensitive to identify improvements or changes in interpersonal relationships in this particular group of participants, or alternatively, that the participants did not experience substantial gains in interpersonal functioning.

The data analysis process was rather straightforward, although the results of the Cronbach's alpha suggest that item 8 should be reverse-coded. The authors could not find any other information about this from an internet search to support the use of reverse-coding for this item. The Cronbach's alpha was calculated for both reverse-coding and 'normal' coding to establish the internal consistency of the scale. One possibility is that even though the translation of the scale from English into Dutch was repeatedly checked, the translation may have resulted in some semantic error which therefore resulted in this puzzling result.

Autonomy, personal growth, environmental mastery and self-acceptance are all concepts which have relevance to transactional analysis and are congruent with the overall goals of transactional analysis, irrespective of the field of specialisation. The present study examined the impact of redecision methods within a personal development workshop format and the findings are consistent with the theoretical and philosophical perspective developed by Goulding & Goulding (1979). Throughout their writing, they emphasised the importance of developing a sense of personal independence and efficacy, self-agency, self-acceptance and an openness to ongoing personal growth through the application of redecision methods within group work contexts. These same areas are those which were demonstrated to have obtained statistically significant change within this study, thus providing contemporary support for the use of redecision theory,

philosophy and methods as a means of promoting personal change.

### Limitations

Although the third questionnaire administration took place on a follow-up day six weeks after the initial workshop, no additional follow-up period was introduced, so it is not possible to state whether participant's changes were long-lasting in nature. A further study which examines stability of change at a six-month (or more) follow-up would therefore be desirable. Also, the participants in this study all originated from a single organisation within one country, which limit generalisability of the findings. Although the sample size was sufficient to conduct a test of statistical significance, it is possible that a larger sample size might have produced different results.

The absence of a control group significantly limits the findings of this present study. The lack of a control group means we cannot identify whether the improvements participants experienced were an artefact of the passing of time and represented natural fluctuations in PWB or whether they were a direct response to the workshop. Similarly, without a matched control group from within the same organisation, we cannot rule out the possibility that improvements in PWB were due to enhancements in working conditions within the company or some other intra-organisational change.

As with the previous study, we recognise that it is possible that some participants may have responded in a way that they (consciously or unconsciously) perceive as socially-desirable, or due to a desire to 'please' the facilitators. Such responses would to some extent bias the participants' responses, particularly as the responses were handed directly to the workshop facilitators. In order to address this, the questionnaires were completed anonymously and placed in a sealed envelope before handing to the workshop facilitators. Nevertheless, despite this 'anonymous submission' procedure, we cannot rule out the potential for such bias. It is also



possible that a positive expectancy bias influenced participants, who may have wished to 'see' a positive effect from the workshop.

An additional matter worthy of discussion is that no participants withdrew or declined to take part in the research. Data attrition and participant withdrawal from research projects is a common occurrence, so the fact that no one withdrew from the present study is somewhat unusual, and cannot be explained. Although the workshop facilitators reported that the group members were interested and enthusiastic about participating in the research, we cannot rule out the possibility that some kind of unspoken social pressure to participate occurred within the group.

The present study only examined outcomes, and did not investigate the process or mechanisms of change. Further research is needed to identify these and to explore ways of improving the effectiveness and efficiency of transactional analysts using redecision methods to facilitate personal change.

## Conclusion

This article has provided statistical evidence supporting the claim that the use of redecision methods in executive coaching workshops can significantly increase participants' subjective psychological wellbeing. Specifically, participants reported statistically significant, positive changes on the scales of autonomy, environmental mastery, personal growth and self-acceptance, and to a lesser extent (non-significant) on the purpose in life scale. These findings support those from a previous article (Widdowson & Rosseau, 2014) which suggested that participants in such workshops experience an increase in personal growth, self-acceptance and psychological wellbeing.

Funding declaration: This research was not funded by any organisation, and none of the researchers were paid specifically for conducting this research.

**Mark Widdowson**, PhD is a Teaching and Supervising Transactional Analyst (Psychotherapy) and a lecturer in counselling and psychotherapy at the University of Salford. He was awarded the 2014 EATA Silver medal for his contributions to the evidence base of the efficacy of TA. He can be contacted on: [m.widdowson@salford.ac.uk](mailto:m.widdowson@salford.ac.uk)

**Peter Theuns**, PhD is a clinical psychologist and associate professor of statistics and research methods at the department of Experimental and Applied Psychology, Faculty of Psychology and Education Sciences of the Vrije Universiteit Brussel, Belgium. His research focuses on survey methodology, and more specifically on the content of lead questions and formal aspects of the accompanying rating scales, such as the labelling of the scale anchors.

**Mil Rosseau**, MSc is a Provisional Teaching and Supervising Transactional Analyst (Educational). He

founded the TA Academic Belgie and BIRD, the Business Institute for Redecision.

**Rik Rosseau** holds a bachelor's degree as a civil engineer and architect. He is co-founder of BIRD, the Business Institute for Redecision. Rik is in TA training as a transactional analyst (Organisational).

## References

- Abbott, R.A., Ploubidis, G.B., Huppert, F.A., Kuh, D., Wadsworth, M.E.J. & Croudace, T.J. (2006) Psychometric evaluation and predictive validity of Ryff's psychological wellbeing items in a UK birth cohort sample of women. *Health and Quality of Life Outcomes*, 4: 76.
- Deci, E.L. & Ryan, R.M. (1985). *Intrinsic motivation and self-determination in human behaviour*. New York: Plenum Publishing Co.
- Deci, E.L. & Ryan, R.M. (2000). The 'what' and 'why' of goal pursuits: human needs and the self-determination of behaviour. *Psychological Inquiry*, 11: 227-268.
- Diener, E. (2009). Subjective well-being. In E. Diener (Ed.), *The science of well-being* (pp.11-58) New York: Spring.
- Dodge, R., Daly, A.P., Huyton, J. & Sanders, L. (2012). The challenge of defining wellbeing. *Journal of Wellbeing*, 2(3): 222-235.
- Goulding, M. & Goulding R. (1979). *Changing lives through redecision therapy*. New York: Grove Press.
- Headley, B.W. & Wearing, A.J. (1992) *Understanding happiness: a theory of subjective well-being*. Melbourne: Longman Cheshire.
- IBM Corp. (2013). *IBM SPSS Statistics for Macintosh, Version 22.0*. Armonk, NY: IBM Corp.
- McNeel, J. (1982). Redecisions in psychotherapy: a study of the effects of an intensive weekend group workshop. *Transactional Analysis Journal*, 12(1): 10-26.
- Noriega-Gayol, G. (1997). Diagnosis and treatment of ego state boundary problems: effects on self-esteem and quality of life. *Transactional Analysis Journal*, 27(4): 236-240.
- Pollard, E. & Lee, P. (2003). Child well-being: a systematic review of the literature. *Social Indicators Research*, 61(1): 9-78.
- Reber, A. (1995). *Dictionary of psychology*, 2nd edition. Harmondsworth: Penguin.
- Rogers, C., Kirshenbaum, V. & Henderson (1990) *The Carl Rogers Reader*. London: Constable.
- Rosseau, M., Rosseau, R. & Widdowson, M. (2014). Application of Redecision Therapy in Executive Coaching Workshops: Part 1 – the Workshop. *International Journal of Transactional Analysis Research*, 5(1) 15-18
- Ryff, C.D. (1989). Happiness is everything, or is it? Explorations on the meaning of psychological well-being. *Journal of personality and social psychology*, 57: 1069-1081.
- Ryff, C.D. & Keyes, C.L.M. (1995). The structure of psychological well-being revisited. *Journal of personality and*

*social psychology*, 69(4):719-727 Ryff scales (retrieved from: [https://www.karger.com/ProdukteDB/katalogteile/isbn3\\_8055/98/53/suppmat/p192-PWB.pdf](https://www.karger.com/ProdukteDB/katalogteile/isbn3_8055/98/53/suppmat/p192-PWB.pdf) accessed on 30 April 2015.

Ryff scales

[https://www.karger.com/ProdukteDB/katalogteile/isbn3\\_8055/98/53/suppmat/p192-PWB.pdf](https://www.karger.com/ProdukteDB/katalogteile/isbn3_8055/98/53/suppmat/p192-PWB.pdf) accessed on 30 April 2015.

Seligman, M.E.P. & Csikszentmihalyi, M. (Eds.). (2000). Positive psychology [Special issue] *American Psychologist*, 55(1).

Springer, K.W. & Hauser, R.M. (2006). An assessment of the construct validity of Ryff's Scales of Psychological Well-Being: method, mode, and measurement effects. *Social Science Research*, 35: 1080-1102.

Suh, E., Diener, E. & Fujita, F. (1996) Events and subjective wellbeing: only recent events matter. *Journal of personality and social psychology*, 70(5): 1091-1102.

van Dierendonck, D., Diaz, D., Rodriguez-Carjaval, R., Blanco, A. & Moreno-Jiminez, B. (2006). Ryff's six-factor model of psychological well-being: a Spanish exploration. *Social Indicators research*, 87: 473-479.

Widdowson, M. & Rosseau, M. (2014). Application of Redecision Therapy in Executive Coaching Workshops: Part 2 - A Qualitative Exploration of Participants' Changes. *International Journal of Transactional Analysis Research*, 5(1) 19-30.

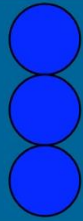

# Combinations of Injunctions and Personality Types Determining Forms of Self-Destructive Behaviour in Alcohol-Dependent Clients: Findings of a Russian Observational Study

© 2016 Dmitri I. Shustov, Olga D. Tuchina, Sergei A. Novikov & Ilya A. Fedotov

## Abstract

*This observational study, conducted 2009-2012 with 190 male out-patient clients diagnosed with alcohol dependence and receiving psychotherapeutic treatment in Ryazan, Russia, investigated whether the patterns of self-destructive behaviours exhibited by the subjects were linked to their Personality Types and which combinations of injunctions were reflected in their main personality traits.*

*Self-destructive behaviour was measured according to the 7 Alcoholic Self-Destructiveness Dimensions (ASD) (Shustov 2005); data on alcohol abuse and preferred ASD were gathered through semi-structured interview; personality patterns and psychosocial functioning were assessed by means of clinical observation, semi-structured interview, the Personality Diagnostic Questionnaire: Version 4+ (Hyer, 1994) (Russian version) and ICD-10 criteria except for Narcissistic Disorder diagnosed according to DSM-IV; 12 injunctions were assessed with The Drego Injunction Scale (Drego, 1994) (Russian version).*

*When correlations were analysed, it was found that injunctions had a significant impact on the hamartic alcoholic script of the out-patient alcohol-dependent clients on the following continuum: Don't Be, Don't Think, Don't Be a Child, Don't Trust, Don't Feel, Don't Grow Up; client personality types had direct relationship with specific injunction patterns. Personality Types mediated the Alcoholic Self-Destructiveness Dimensions: the Classical Suicidal Dimension being associated with Borderline personality traits; Antisocial with the Antisocial personality; and Professional with the Narcissistic Personality.*

## Key words

psychotherapy, substance use disorders, alcohol dependence, suicide, injunctions, personality disorders, adaptations, transactional analysis, self-destructive behaviour, Russia.

## Background

Today, psychotherapy for alcohol dependence and alcohol use disorders in general includes many evidence-based approaches and methods (e.g. NIDA - National Institute of Drug Abuse, 2012). Most of these evidence-based psychotherapies are cognitive behavioural (CBT) methods focusing on distress or relapse prevention, recognition and management of alcoholic triggers as well as coping with negative emotions and cravings (Magill & Ray, 2009). Personality-oriented methods involve reparative work on dissociation and early traumas suffered in dysfunctional families or as a result of different kinds of abandonment (Najavits, 2013). There are also combined approaches such as disulfiram (antabuse) contracts in behavioural couple's therapy for alcoholism (O'Farrell & Clements, 2012), behavioural self-control training or other CBT interventions combined with naltrexone, nalmephepene or other medications (Niciu & Arias, 2013). In TA terms, most of these evidence-based methods focus on decontamination, strengthening the resources of the Adult ego state, On the other hand, therapists and clients are less aware of transference which develops within a lasting therapeutic relationship and makes it possible for the therapist's figure to be introjected into the client's Parent (P2) along with new permissions (Crossman, 1966). Unfortunately, official medicine and the Alcoholics Anonymous community consider cases of alcoholic script redecision and cure achieved by clients to be casuistry.

At the same time, current epidemiological research suggests that there are multiple outcomes of alcohol dependence or harmful alcohol use among clients. Few people with clinical symptoms of alcohol dependence apply for Substance Use Disorders treatment (SUD treatment) (NIAAA – National Institute on Alcohol Abuse and Alcoholism, 2006). About two thirds of them cure alcohol dependence (through controlled drinking or complete abstaining) naturally, without any professional help (Cunningham, Breslin & Curtis, 2004). An opinion that alcohol dependence is, first and foremost, a chronic disease with poor treatment outcome, has been based mainly on the findings of observation of 'difficult' patients seeking treatment and usually having comorbid disorders, whereas the situation at the population level is completely different (Cunningham & McCambridge, 2012).

Berne (1981) challenged the medical paradigm of alcohol dependence as early as the middle of the 20th century. He argued that this pessimistic model justified doing nothing during the treatment of that 'incurable disease' and suggested giving up all 'labels and diagnoses' and analysing a game of 'Alcoholic'. "In game analysis there is no such thing as "alcoholism" or an "alcoholic", but there is a role called the Alcoholic in a certain type of game" (p.30).

Elaborating on Berne's ideas, Steiner (1974) described an 'alcoholic' life script as a curable alternative to alcohol dependence: "Like diseases, scripts have an onset, a course, and an outcome. Because of this similarity, scripts have been mistaken for diseases. However, because scripts are based on consciously willed decisions rather than on morbid tissue changes, they can be revoked or "undecided" by similarly willed decisions. Thus, I believe that a cured alcoholic (though he often does not choose to) will be able to return to social drinking, while the person who returns to uncontrollable drinking after one drink has been essentially unable to dispose of his script" (p.17).

Steiner believed that the main 'alcoholic' injunction was 'Don't Think' actualising in frustrating situations, triggering drinking and, therefore, preventing people from solving issues in the here-and-now, i.e. decathecting the Adult ego state. Furthermore, Steiner mentioned the role of the 'Don't Be' injunction in people with so-called hamartic life scripts, emphasising their inclinations to different self-destructive behaviours. It is interesting that at the beginning of the 20th century, an observation that alcohol-dependent people were at high risk of suicide or other self-destructive behaviours enabled Menninger (1993) to call this condition a form of 'chronic suicide'.

Comparing data received in a therapeutic situation in a group of alcohol-dependent clients (n=135) and a group of non-alcohol-dependent controls (n=49), we found that 45% of alcohol-dependent clients had the 'Don't Be' injunction versus 21.7% of the controls (intergroup differences were significant at  $p = 0.02$ ) (Shustov, 2000). The 'Don't Be' incidence increased on the following continuum (at the statistical significance level of  $p < 0.05$ ):

- clients without suicidal ideation (34%);
- clients with suicidal ideation (38.8%);
- clients with suicidal attempts (95.6%).

Elaborating on our research, we used exploratory factor analysis to single out historical, psychological and clinical variables that were associated with classical suicidal behaviour in alcohol-dependent patients. Variables with highest factor weights represented a wide range of phenomena (e.g. multiple bone fractures, birth defects, inferiority complex, etc.), and thus we hypothesised that self-destructive activity in alcoholics might be multidimensional. That is, it would not limit itself to conscious somatic self-destruction through suicides and suicidal attempts alone, but might actualise through professional failures or family system collapses. Using clinical analysis and semantic matching, we grouped these relevant factors according to seven dimensions: Classical Suicidal Self-Destructiveness; Family Self-Destructiveness; Somatic Self-Destructiveness; Risky Behaviour; Antisocial Behaviour; Professional Self-Destructiveness; Dual Diagnosis. We also thoroughly studied additional characteristics of clients demonstrating self-destructive behaviours within the above dimensions (Shustov, 2005, 2009; Merinov & Shustov, 2012; Shustov, Merinov & Tuchina, 2015). Grouping and additional factor characteristics of the Alcoholic Self-Destructiveness Dimensions (ASD) are provided below.

At the same time, the described variability of the behavioural forms of Alcoholic Self-Destructiveness was to be explored at the intrapsychic level. We assumed that the choice of the ASD depended on a combination of different injunctions, with 'Don't Be' reflecting the main pattern of the client's personality traits, i.e. the Personality Type. This hypothesis was based on two premises. Firstly, alcoholics who commit fatal suicide generally have no serious alcohol-related somatic medical conditions whereas high density of alcohol-related illnesses in the general population of alcohol-dependent patients is a well-known fact. Research shows that medical illnesses reinforce suicidal ideation and planning, but they are not related to an increase in the number of suicidal attempts (Pompilli et al, 2010). Our own post-mortem study of suicidal patients with alcohol dependence revealed few patients with severe somatic conditions and burn injuries (Shustov, 2000), although up to 40-50% patients of burns units are people with alcohol use disorders (Davis & Loxton, 2013; Egorov, Krupitsky, Sofronov, Bobrov, Tyavokina & Dobrovolskaya, 2013). In other words, it can be assumed that the choice of the way of death is scripty: those who decide to die from alcohol-related destruction of the viscera do not commit suicide.

Secondly, it is known that specific features of self-destructive behaviour are related to specific personality types, e.g. borderline, antisocial, narcissistic personalities etc. (Chachamovich, Ding & Turecki, 2012; Larkin, Di Blasi & Arensman, 2014; Wedig, Silverman, Frankenburg et al, 2012). Therefore, different ASDs might depend on the structure of clients' personality.



There are multiple definitions of personality and personality types and multiple approaches to their classification, usually accounting for the continuum existing between the 'norm' (commonly described as styles, adaptations and types) and the 'pathology' (disorders, psychopathy, etc). In TA, personality types are generally described in terms of the Personality Adaptations concept (Ware, 1983; Joines, 1986, 1988; Hoyt, 1989; Joines & Stewart, 2002). In the Russian academic tradition, this concept is very close to the term "personality accentuation" introduced by Leonhard (1968) and specified by Russian psychiatry researchers as denoting an extreme variant of normal psychological functioning, when separate personality traits get so intense that the person becomes vulnerable to specific psychological and social triggers, whilst at the same time remaining continually, and sometimes highly, resilient to all the other triggers (Lichko, 1983). Therefore, the TA concept of personality adaptations is consistent with the traditions of the Russian medical research and was employed as a qualitative measure of personality by some Russian researchers (Agibalova, Buzik & Gurevich, 2011; Novikov, 2014). Thus, for the purposes of our study, the Personality Type was defined as a pattern of stable personality traits that would determine the individual's psychosocial functioning and would lie on a 'norm-pathology' continuum ranging from Personality Adaptation Trends through Personality Adaptation to Personality Disorders (see Methods for research definitions).

## Research Question and Objectives

Taking into account this background, the research question of the current study was how a combination of the Don't Be with other injunctions would change depending on alcohol-dependent clients' Personality Types. To answer the question, the following study objectives were generated:

1. To identify the range of injunctions found in alcohol-dependent clients;
2. To assess the relationship between these injunctions and clients' Personality Types;
3. To assess the relationship between Personality Types and Alcoholic Self-Destructiveness Dimensions.

## Funding and Ethical Considerations

The study was approved by the Ethics Committee of the Ryazan State Medical University. All clients agreed to participate in the study on a voluntary basis and signed Informed Consents for participation. The confidentiality principle was observed. Clients had the right to withdraw from the study at any stage. Ethical issues were controlled for through the use of contracts that provided for the terms, timing, and responsibilities of the parties during the study and the treatment involved. If necessary (history of suicidal attempts, suicidal ideation and suicidal trends, self-injuries, history of suicides in close relatives, etc), no-suicide or no-harm contracts were made.

## Methodology

The material presented in this article (Study B) is part of a larger study (Study A) aimed at developing guidelines for the psychotherapeutic treatment accounting for Alcoholic Self-Destructive and Personality Types in alcohol-dependent men (Figure 1). The objectives of both Study A and Study B were achieved through using observational research design (cohort study). Study A investigated relationships between Alcoholic Self-Destructiveness and Personality Types in three cohorts of clients: clients with Personality Adaptation Trends; clients with Developed Personality Adaptations; clients with Personality Disorders. It also evaluated the therapeutic outcome of a brief psychotherapeutic anti-alcohol intervention equivalent in the three groups and aimed at reduction of cravings for alcohol.

### The sample

The studied sample consisted of 190 male clients, mean age 37 (9.4; 21÷64). The inclusion criteria were male sex; the diagnosis of alcohol dependence based on ICD-10 criteria (F10.2) (World Health Organisation, 1992); informed consent to participate. The clients displaying signs of organic CNS disorder, acute psychosis, severe somatic conditions and women were excluded from the study. We excluded women to achieve homogeneity of the sample as there are clear gender differences in manifestations of self-destructiveness, such as findings that indicate the suicide risk in men is ten times that of women (Kocić, Radovanović S, Vasiljević et al, 2012).

All clients in the sample (N=190) participated in a psychotherapeutic interview. 46 people (24.2%) dropped out of the study after Stage 1 and refused from the therapy. The drop-out after Stages 1 and 2 was not significant for Study B, as it was based on the whole sample's data, and data remained valid as all clients had given informed consent to the study and the use of their data after possible withdrawal.

### Procedure

Study B drew on the data of the heterogeneous cohort of all Study A clients, which is therefore described here. We performed **Study A** in 2009-2012 among 190 male clients who applied for anonymous out-patient brief psychotherapy for alcohol dependence in Ryazan, an industrial and academic city in the central part of Russia, with 600000 citizens. To minimize the impact of affective disorders typical of the acute alcohol withdrawal stage, clients were examined from days 7 to 14 of abstinence.

Study A schedule for every client followed the logic of the psychotherapeutic process: Administrative Contracting and Psychotherapeutic Interview (Stage 1st Session); Therapeutic Contracting (Stage 2); Brief Intervention (Stage 3); Follow-up and Supportive Psychotherapy (Stage 4) (Figure 1).



## STUDY A

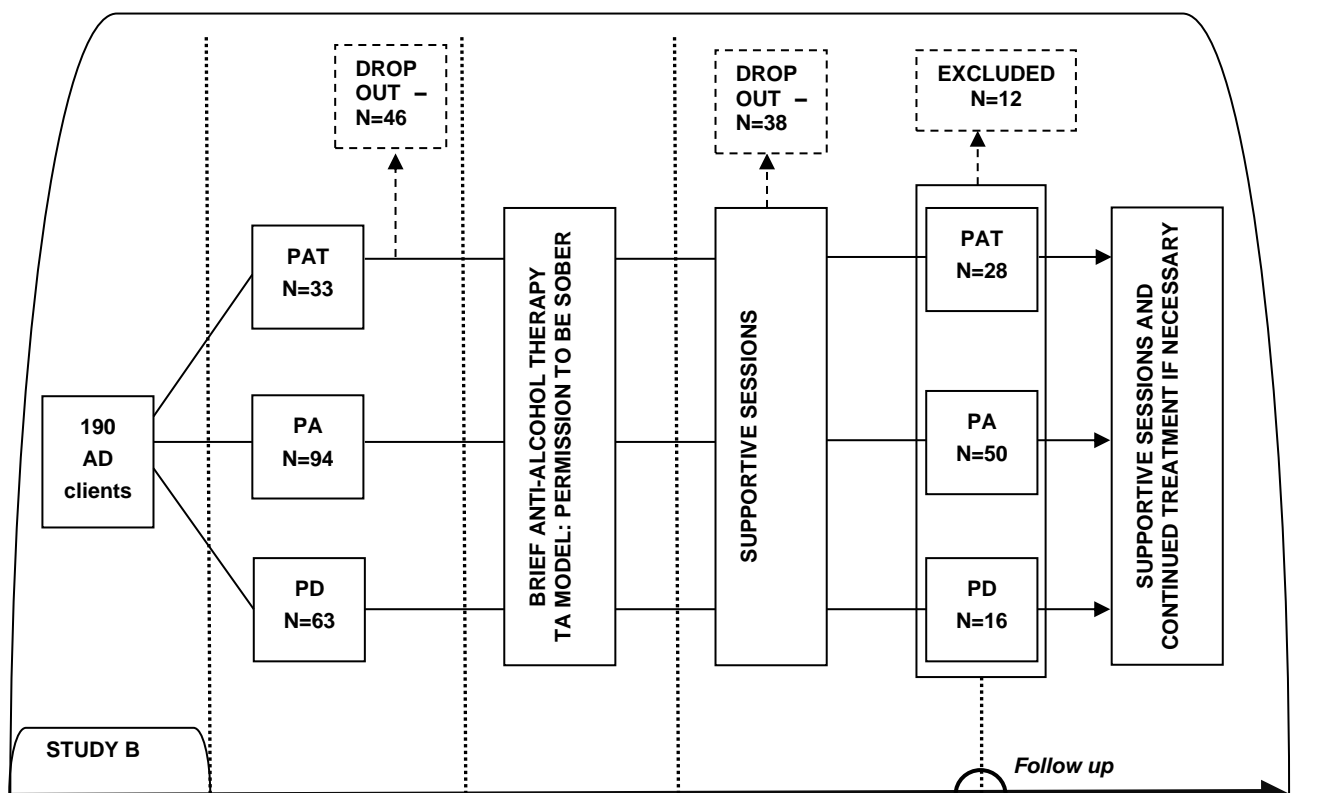

### STAGE 1 – Session 1

Administrative contracting.  
Data gathering.  
Data analysis.  
Client qualification according to main variables.  
Assessing correlations.

### Please, note:

Drop-out – Number of clients who withdrew from treatment

Excluded – clients excluded from analysis because they needed medication treatment at some stage of the study  
AD – alcohol-dependent; PAT – Personality Adaptation Trends; PA – Personality Adaptation; PD – Personality Disorder

Figure 1. Study design and scheduling

During Stage 1, a psychotherapist, who was responsible for the client's therapy later, conducted a therapeutic interview with the client, gathering information on his social and demographic characteristics, history of alcohol abuse, self-destructive behaviour, personality type and negative parental messages received in childhood.

**Study B** drew on Study A but for Stage 1 had several research sub-stages:

- data gathering;
- statistical processing of the data: descriptive statistics, analysing correlations;
- data interpretation.

Therapy sessions at Stages 2 and 3 lasted from 45 minutes (usually) to 90 minutes if there was a need to work through intensive emotions such as fear of death, anger, guilt and shame (Type 2 decontamination – Adult-Child

Decontamination). If necessary, a therapist used parenting to provide for Type 1 decontamination (McNeel, 1976; Osnes, 1974). No-suicide/homicide/etc contracting usually concluded brief decontamination work. Brief therapy for alcohol dependence accounted for the effect of expectations (placebo effect) which is one of the main non-specific (common) active ingredients of psychotherapy (Constantino, Ametrano & Greenberg, 2012). Utilization of the placebo effect in therapy is based on clients' experiences and expectations that widespread medical procedures, i.e. such as treatment with medication or special devices, would be efficient and would help them (Benedetti, 2013). In our case, during the last session of Stage 3, clients received one session of Transcranial Magnetic Stimulation (TMS) suggested for the treatment of alcohol dependence (Mishra, Nizamie, Das & Praharaj, 2010). TMS was accompanied with a verbal statement of the danger of using alcohol after the

TMS session (it is important to note that preliminary no-suicide contracting was a prerequisite for this work in order to prevent 'suicidal' intentional manipulative drinking). The overarching goal of this approach was to give a new therapeutic permission (through introjections of the therapist's image into the client's P2) shaped as the following statement (or a command!), "You can live a sober life".

Generally, Stage 3 - the active stage of therapeutic interventions – lasted no longer than 30 days (1-2 sessions a week), followed with supportive 30-minute interventions once in 3 or 4 months during 12 months, and once in 6 months throughout the following years of therapeutic remission from alcohol dependence. The follow-up data gathering for every client was performed 12 months after the study onset .

### Variables and measures

The main Study B variables were qualitative, categorical, dichotomous data. The general principle of qualifying the variables (described below) was that the researchers took into account the whole set of the data gathered, including those obtained via psychodiagnostic testing, semi-structured interview, clinical observation, history analysis, medical documentation provided by the clients, and conversations with relatives (with client agreement).

Psychodiagnostic testing included three measures: a validated Russian version of the Personality Diagnostic Questionnaire – Version 4+ (Hyler, 1994); the Questionnaire of Present and Past Suicidal and Non-Suicidal Behavioural Manifestations (Shustov, Merinov & Valentik, 2000), and the Drego Injunction Scale (Drego, 1994). The applied version of PDQ-4 was translated into Russian and validated by Dvorshchenko (2008) and has been used in personality disorders research in Russia. The Questionnaire of Present and Past Suicidal and Non-Suicidal Self-Destructive Behavioural Manifestations was developed by one of the authors (Shustov) and validated in terms of a study of alcoholic self-destructiveness in a sample of patients with alcohol dependence. It was approved by the Russian Ministry of Health for diagnosis of self-destructive behaviour. The Russian version of the Drego Injunction Scale was not subject to a special validation procedure save for evaluation of the equivalence of translation from English into Russian by a linguist and a psychologist with TA knowledge. The Drego Scale was used mostly for informative purposes to help the investigators make a more accurate diagnosis of the subjects' parental injunctions.

*Self-destructive behaviour* was measured according to the 7 Alcoholic Self-Destructiveness Dimensions (Shustov, 2005):

1. Classical Suicidal Self-Destructiveness displaying as self-injury (clients with a history of suicides, suicidal attempts, suicidal ideation and tendencies).
2. Family Self-Destructiveness: the factor of divorce and being divorced at the time of examination, subjective evaluation of the marriage as an unhappy one, childlessness, feelings of isolation and hopelessness.

3. Somatic Self-Destructiveness: presence of a moderately severe chronic somatic condition or multiple conditions, consequences of domestic burns, multiple surgeries, amputations, experiencing somatic and mental inferiority complex.

4. Risky Behaviour: multiple bone fractures (more than two), history of head injury with loss of consciousness, accidents, conscious inclination to risk, use of alcohol surrogates and alcohol poisoning with hospitalising into Emergency Unit.

5. Antisocial Behaviour: episodic use of illegal drugs, provocation of physical violence (including provoking police officers), history of conviction, conscious ability to violate social moral standards, proneness to stealing, being aggressive both when sober and under alcohol intoxication.

6. Professional Self-Destructiveness: loss of job within the last year and unemployed as at the date of examination, belief in immortality of the products of their work.

7. Dual Diagnosis Group: visiting a psychiatrist to treat mental disorder (save for alcohol dependence), diagnosis of a comorbid mental disorder, Post-Traumatic Stress Disorder, head injury consequences, depressive episodes, episodic use of illegal drugs, history of alcohol-related psychosis, withdrawal-related paroxysmal disorders.

The data on alcohol abuse and preferred ASD were gathered through semi-structured interview based on the Questionnaire of Present and Past Suicidal and Non-Suicidal Self-Destructive Behavioural Manifestations (Shustov, Merinov & Valentik, 2000). The Questionnaire consists of 3 sections: General Information, Substance Use and Alcoholic Self-Destructiveness Dimensions. The client and the practitioner filled out the Questionnaire during the non-directive interview demonstrating protective and reparative aspects of the therapeutic process. The researchers assessed the interview data from the clinical perspective and identified ASDs the client preferred taking into account objective and subjective information.

*Personality type*: variables to describe Personality Types reflected the norm-pathology continuum Personality Adaptation Trends (Normal Functioning) - Personality Adaptations - Personality Disorders. Thus, we assumed that there might be at least three categories of people on the norm-pathology continuum:

- Clients with Personality Adaptation Trends – whose functioning can be described as 'normal' but having traits of Personality Adaptations actualized in certain, usually emotionally intensive, situations;
- Clients with Personality Adaptation - individuals with expressed traits of Personality Adaptations visible in their daily functioning;
- Clients with Personality Disorders.

For the purposes of the study, we adopted Tilney's (1998) definition of Personality Adaptation as "a structuring of the personality that is compatible with normal functioning but shows similarities to certain types of psychological disorder" (p.88).

Personality Disorder was defined as "an enduring pattern of inner experience and behaviour that deviates markedly from the expectations of the individual's culture, is pervasive and inflexible, has an onset in adolescence or early adulthood, is stable over time, and leads to distress or impairment" (American Psychiatric Association, 1994, p.629).

The following Personality Types were measured: Paranoid, Schizoid, Dissocial (Antisocial), Emotionally Unstable (Borderline), Histrionic, Anankastic (Obsessive-Compulsive), Anxious (Avoidant), Dependent, Narcissistic, and Passive-Aggressive.

The method of *semi-structured interview* allowed the collection of information on the clients' personality patterns and specific features of their psychosocial functioning. As an objective measure to assess the personality type, we used a validated Russian version of the Personality Diagnostic Questionnaire – Version 4+ (Hyler, 1994; Dvorshchenko, 2008) and the ICD-10 criteria, save for Narcissistic Disorder diagnosed according to DSM-IV criteria, as it is not included in ICD-10.

*Early Negative Parental Messages.* We adopted Goulding & Goulding's (1979) definition of injunctions as "messages from the Child ego state of parents, given out of the circumstances of the parent's own pains" (p.34) and assessed 12 injunctions using The Drego Injunction Scale (Drego, 1994). Due to an uncertain validity of the Russian version of the Drego Scale, the psychotherapist used the results of the corresponding assessment as an informative secondary measure whilst basing the diagnosis of the subjects' parental injunctions on the clinical interview and observation.

### Statistical analysis.

Study B descriptive statistics: The authors calculated mean scores (M), standard deviations (SD), minimum and maximum scores for social and demographic data such as age, duration of alcohol use, mean age of alcohol dependence onset, etc.

To study relationships between ASD, Personality Types and Injunctions, we analysed correlations using contingency tables as most data was dichotomous. For the same reason, the significance of differences between proportions was tested by means of Fisher's exact test and Pearson's chi-squared method. The null hypothesis was rejected if the differences were significant at the level of  $p < 0.05$ .

Table 1 indicates the personality types for Study B subjects.

Personality Type	Number of People	% of the Total
Borderline	42	22.1%
Antisocial	32	16.8%
Paranoid	20	10.6%
Narcissistic	15	7.9%
Anxious (Avoidant)	14	7.3%
Obsessive-Compulsive	12	6.3%
Schizoid	11	5.8%
Histrionic	9	4.5%
Dependent	1	0.5%
Passive-Aggressive	1	0.5%
Personality Adaptation Trends	33	17.4%
<b>Total</b>	<b>190</b>	<b>100%</b>

*Table 1. Study B Subjects' Personality Types Distribution (N=190)*

The clients with Personality Adaptation Trends were excluded from Study B analysis as the PA traits were so insignificant that there might have been a high level of bias during their classification on the part of investigators. The clients with Dependent, Passive-Aggressive and Histrionic types were also excluded as the number of observations was insufficient (less than 10) to assess the relationships between studied variables. Clients could be diagnosed with several Personality Adaptations. In this case, a domineering Personality Adaptation alone was used for the following assessment. Thus, 146 clients were assessed in Study B.

## Results

We identified which Parental injunctions the alcohol-dependent subjects had and assessed the frequency of their occurrence as illustrated in Table 2.

Table 3 shows correlations (r) between Personality Types and Injunctions in the Alcohol-Dependent Clients; Table 4 indicates the major patterns identified, and Table 5 contains correlations between the Personality Types and ASD

We identified three statistically significant positive relationships:

1. Borderline clients' typical injunctions were 'Don't Be Yourself', 'Don't Grow Up', 'Don't Think', 'Don't Be Healthy'. Combined with 'Don't Be' and alcohol dependence, these injunctions displayed mostly as Classical Suicidal Self-Destructiveness.
2. Narcissistic clients had such typical injunctions as 'Don't Be Yourself', 'Don't Be Close', 'Don't Feel', 'Don't Trust'. Combined with 'Don't Be' and alcohol dependence, these injunctions displayed mostly as Alcoholic Professional Self-Destructiveness.

Note:

*Italic Green* type and \* indicate significant positive correlations (r is significant at p<0.05).

*Italic Red* type and \* indicate significant negative correlations (r is significant at p<0.05).

N – number of people with a relevant personality type.

Injunctions	Number of Observations	Frequency, %	Injunctions	Number of Observations	Frequency, %
Don't Be	100	52.6	Don't Be Important	24	12.6
Don't Think	73	38.4	Don't Be Yourself	22	11.6
Don't Be a Child	54	28.4	Don't Belong	22	11.6
Don't Trust	53	27.9	Don't Be Close	20	10.5
Don't Feel	43	22.6	Don't Be Healthy	15	7.9
Don't Grow Up	39	20.5	Don't	8	4.2

Table 2. Injunctions Identified in Alcohol-Dependent Clients

Injunctions \ Personality Type	Injunctions										
	Don't Be	Don't Be Yourself	Don't Grow Up	Don't Be a Child	Don't Be Important	Don't Be Close	Don't Feel	Don't Be Healthy	Don't Belong	Don't Trust	Don't Think
Paranoid (N=20)	<i>-0.155*</i>	0.037	-0.089	0.088	-0.079	-0.062	-0.104	0.027	0.037	<i>0.513*</i>	<i>-0.165*</i>
Schizoid (N=11)	-0.036	-0.090	-0.070	0.044	-0.094	<i>0.135*</i>	0.027	-0.073	<i>0.544*</i>	-0.104	<i>-0.149*</i>
Borderline (N=42)	<i>0.378*</i>	<i>0.204*</i>	<i>0.138*</i>	<i>-0.251*</i>	-0.050	-0.100	-0.015	<i>0.361*</i>	-0.193*	-0.077	<i>0.361*</i>
Antisocial (N=32)	<i>0.230*</i>	<i>-0.163*</i>	<i>-0.194*</i>	-0.034	0.083	-0.017	<i>0.160*</i>	-0.080	-0.163*	-0.092	<i>0.252*</i>
Narcissistic (N=15)	<i>-0.152*</i>	<i>0.138*</i>	0.045	-0.098	0.065	<i>0.154*</i>	<i>0.261*</i>	-0.013	-0.106	<i>0.123*</i>	-0.031
Anxious (N=14)	<i>-0.257*</i>	0.024	<i>0.256*</i>	<i>-0.133*</i>	<i>0.135*</i>	0.035	0.040	-0.083	<i>0.402*</i>	-0.041	-0.140*
Obsessive-Compulsive (N=12)	-0.057	-0.094	<i>-0.132*</i>	<i>0.412*</i>	-0.099	0.052	-0.089	-0.076	-0.094	-0.017	<i>-0.205*</i>

Table 3. Correlations between Personality Types and Injunctions

Personality Type	Injunction Patterns
Paranoid (N=20)	Don't Trust
Schizoid (N=11)	Don't Be Close, Don't Belong
Borderline (N=42)	Don't Be, Don't Be Yourself, Don't Grow Up, Don't Be Healthy, Don't Think
Antisocial (N=32)	Don't Be, Don't Feel, Don't Think
Narcissistic (N=15)	Don't Be Yourself, Don't Be Close, Don't Feel, Don't Trust
Anxious (N=14)	Don't Grow Up, Don't Be Important, Don't Belong
Obsessive-Compulsive (N=12)	Don't Be a Child

Table 4. Major Patterns of Injunctions Depending on Personality Types

Note:

*Italic Green* type and \* indicate significant positive correlations (r is significant at p<0.05).

*Italic Red* type and \* indicate significant negative correlations (r is significant at p<0.05).

N – number of people with a relevant personality type.

Personality Disorder	Borderline N=42	Antisocial N=32	Narcissistic N=15	Schizoid N=11	Paranoid N=20	Anxious N=14	Obsessive-Compulsive N=12
<b>Self-Destructiveness</b>							
Suicidal (N=40)	0.223*	0.044	-0.103	0.038	-0.051	<i>-0.146*</i>	-0.028
Family (N=68)	0.079	0.016	-0.015	-0.044	0.102	0.126	-0.104
Somatic (N=40)	-0.057	-0.060	-0.103	0.073	0.075	0.101	0.025
Risky (N=63)	0.089	0.107	0.004	<i>-0.173*</i>	-0.019	-0.110	0.142
Antisocial (N=53)	0.008	<i>0.347*</i>	-0.052	-0.054	-0.060	-0.041	-0.017
Professional (N=43)	-0.137	-0.109	<i>0.215*</i>	0.027	0.019	0.040	0.015

**Note** that the clients could display signs of different self-destructive behaviours. The analysis took into account all of them, therefore the number of observations in Alcoholic Self-Destructiveness Dimensions exceeds the number of clients classified according to the personality types.

Table 5. Correlations between Personality Types and ASD

3. Antisocial clients' most frequent injunctions were 'Don't Feel', 'Don't Think'. Combined with 'Don't Be' and alcohol dependence, these injunctions displayed mostly as Antisocial Behaviour.

The only two significant negative correlations were identified between the Schizoid personality and the Risky Behaviour Dimension, and the Anxious personality and Classical Suicidal Dimension.

## Discussion

As to the first study objective, we have identified a pattern of injunctions characteristic of the alcohol-dependent clients. These are 'Don't Be', 'Don't Think', 'Don't Be a Child', 'Don't Trust', 'Don't Feel' and 'Don't Grow Up'. It is quite possible that this pattern, especially 'Don't Be' and 'Don't Think', may underlie alcohol dependence. Other injunctions (and their combinations with the foregoing), which we call "mediator" injunctions, may determine alcohol-dependent clients' personality structure and mediate the way the latter injunctions actualise themselves through Alcoholic Self-Destructiveness Dimensions (see Figure 2).

Alternatively, the incidence of 'Don't Be' as measured with the Drego Questionnaire in the alcohol-dependent outpatients was equivalent to our former data obtained purely through clinical observation and interview (Shustov, 2000). It appears that this result reflects the fact that there may be a most self-destructive pool of alcohol-dependent clients. In their case, therapeutic observation and intervention may need to account for the same principles as observation and intervention in oncology (Meehan, 1990).

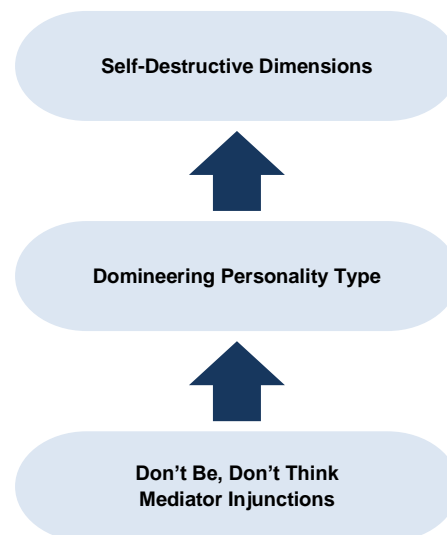

Figure 2. Self-Destructiveness as determined by Personality

Pursuing the second objective has enabled us to single out patterns of injunctions characteristic of the different Personality Types. It is evident that the statistically significant injunctions identified are compatible with the clinical reality of the Personality Types. Thus, the core injunction of the Paranoid clients – 'Don't Trust' - reflects their suspiciousness and jealousy. 'Don't Be Close' is indicative of the Schizoid detachment and withdrawal from contact. Injunctions typical of the Borderline clients are helpful for understanding their challenges related to survival, identity and separation. Injunctions of the Antisocial clients indicate their tendencies to self-destruction, repression of feelings, and behaving without consideration of consequences. The identified



injunctions are most apparent in the clinical observation of the Narcissistic, as well as Anxious clients – with their fear of contact ('Don't Belong') and capacity for regression in response to a threatening stimulus ('Don't Grow Up'). The key injunction of the Obsessive-Compulsive clients excludes flexibility, creativity and risk in decision-making.

We identified multiple significant negative correlations between the Personality Types and injunctions. Sometimes they comply quite well with the clinical reality, e.g. 'Don't Grow Up' is found to be untypical of the Obsessive-Compulsive and Antisocial personalities. Alternatively, these findings contradict the clinical reality and need to be conceptualised and investigated further. For instance, we have found that the incidence of 'Don't Be' in Paranoid clients is decreased, although there is evidence for jealousy-related suicidal and homicidal behaviour in Paranoid alcohol-dependent clients (Jiménez-Arriero, Hernández, Mearin Manrique, Rodríguez-Jiménez, Jiménez Giménez & Ponce Alfaro, 2007). As to Narcissistic clients, who display low incidence of 'Don't Be' as well, seemingly they tend to avoid classical suicidal activity as evidenced by the relevant correlations, and engage in a 'less dangerous' professional self-destruction. In any case, investigating other script components – counter-injunctions and program – and their interaction with injunctions, might be helpful to eliminate some contradictions found in the study.

It would also be interesting to measure whether there is quantitative difference (or equivalence) in injunctions in clients with Personality Adaptations and clients with Personality Disorders. In this way we could assess the weight of any environmental or inherited biological factors in the genesis of alcohol dependence, which Davis and Loxton (2013) propose to be a 50:50 ratio. We were unable to assess it within this study, due to an insufficient sample size among other things

We have found a connection between Personality Types and ASD. For instance, Borderline persons actualise their deadly scripts through the Classical Suicidal Self-Destructiveness as confirmed by multiple clinical data on an increased incidence of suicides in Borderline clients, with even more if Borderline Personality Disorder is combined with alcohol dependence, (Preuss, Koller, Barnow, Eikmeier & Soyka, 2006). As was expected, clients with Antisocial personality actualize their hamartic script through the Antisocial Dimension. Antisocial behaviour and alcohol dependence reinforce each other, and these clients frequently become victims of homicide, police brutality and imprisonment. Narcissistic clients actualize their self-destructive script through not OKness in the area that is most relevant for them, i.e. their profession, as the drive for destruction sustained with alcohol creates a context for losing one's favourite job, exposure to humiliating persecutions and dismissals. Thus, a vicious circle that reinforces drinking and its circumstances, is born.

Unfortunately, other hypothesized connections assumed by us and based on clinical observations (e.g. between the Paranoid personality type and Family Self-Destructiveness; Histrionic personality and Risky behaviour, Schizoid personality and Dual Diagnosis) have not been confirmed statistically.

## Limitations of the study

As has been mentioned in the discussion, one limitation of our study was related to the small sample. It was enough to study the main variables and answer the research question but some questions that appeared during the study have remained unanswered: what relationships could be found if clients with the Dependent, Passive-Aggressive and Histrionic Personality Types had been included in the study; how their inclusion would influence the main pattern of alcoholic mediator injunctions; what is the ratio between environmental and hereditary factors in the origin of alcohol dependence; how different are injunction patterns in alcohol-dependent clients with Personality Adaptations and Personality Disorders, and are they different from the 'normally functioning' alcohol-dependent individuals?

Another limitation was the homogeneity of the sample. We excluded women from our study and the sample consisted mostly of highly motivated male clients who applied for the anti-alcohol treatment independently. Thus, this sample may not be representative of the real population of alcohol-dependent clients, lacking especially in-patients, who are often low-motivated, forced to receive treatment by their relatives, employers or other authorities and displaying signs of comorbid disorders (PTSD, major depression, etc).

The last limitation (and, again, a new research perspective), deals with mediators influencing the personality structure and the choice of ASD in alcohol-dependent clients. We have studied only one component of the script system, leaving counter-injunctions and program unattended. A detailed empirical study of the script system components and their patterns within a well-organized research using both quantitative and qualitative measures (rather than pure clinical observation) may be needed to fully understand relationships between personality structuring and self-destructive behaviour in alcohol-dependent clients.

## Conclusion

There are a number of injunctions that contribute significantly to the hamartic alcoholic script of the out-patient alcohol-dependent clients on the following continuum from the most to the less frequent: Don't Be, Don't Think, Don't Be a Child, Don't Trust, Don't Feel, Don't Grow Up. Our findings suggest that alcohol-dependent clients' personality types are positively associated with unique and specific injunction patterns. We have also found that personality types act as mediators for the corresponding Alcoholic Self-Destruct-

iveness Dimensions: the Classical Suicidal Dimension is mediated with the Borderline personality traits; Antisocial with the Antisocial personality; and Professional with the Narcissistic Personality.

**Dmitri I. Shustov**, MD, PhD, TSTA (Psychotherapy), Professor, Chair of the Department of Psychiatry of the Ryazan State Medical University can be contacted on [dmitri\\_shustov@mail.ru](mailto:dmitri_shustov@mail.ru)

**Olga D. Tuchina**, Psychologist, Lecturer at the Department of Medical and Social Rehabilitation for Substance Use Disorders of the People's Friendship University of Russia, is in training as a Certified Transactional Analyst (Psychotherapy).

**Sergei A. Novikov**, MD, PhD is in training as a Certified Transactional Analyst (Psychotherapy).

**Ilya A. Fedotov**, MD, PhD is in training as a Certified Transactional Analyst (Psychotherapy).

## References

Agibalova, Tatiana V., Buzik, Oleg Zh. & Gurevich, Gennady L. (2011). *Znachenie lichnosti bol'nykh alkoholizmom v psihoterapevticheskom processe* [Psychotherapy of alcoholics based on personality traits]. *Zhurnal nevrologii i psikiatrii imeni S.S. Korsakova*. 11, 39-43. [in Russian]

American Psychiatric Association (1994). *Diagnostic and Statistical Manual of Mental Disorders, Fourth Edition*. Washington DC: American Psychiatric Association: Author.

Benedetti, Fabrizio. (2013). Placebo and the new physiology of the doctor-patient relationship. *Physiological Reviews*. 93:3, 1207–1246.

Berne, Eric. (1981). *Games people play: The psychology of human relationships*. New York, NY: Grove Press.

Chachamovich, Eduardo, Ding, Yang, Turecki, Gustavo. (2012). Levels of aggressiveness are higher among alcohol-related suicides: results from a psychological autopsy study. *Alcohol*. 46:6, 529-536.

Constantino, Michael J., Ametrano, Rebecca M. & Greenberg, Roger P. (2012) Clinician interventions and participant characteristics that foster adaptive patient expectations for psychotherapy and psychotherapeutic change. *Psychotherapy*. Vol. 49: 4 557–569.

Crossman, Patricia. (1966). Permission and Protection. *Transactional Analysis Bulletin*. 5:19, 152-154.

Cunningham, John A. & Breslin, F.Curtis. (2004). Only one in three people with alcohol abuse or dependence ever seek treatment. *Addict. Behav.* 29, 221-223.

Cunningham, John A. & McCambridge, Jim. (2012). Is alcohol dependence best viewed as a chronic relapsing disorder? *Addiction*. 107: 6-12.

Davis, Caroline, Loxton, Natalie J. (2013). Addictive behaviors and addiction-prone personality traits: Associations with a dopamine multilocus genetic profile. *Addictive Behaviors*. 38:7, 2306–2312.

Drego, Pearl. (1994). *Happy family: Parenting through family rituals*. Bombay: Alfreruby Publishers.

Dvorshchenko, Valery P. (2008). *Diagnosticheskij test lichnostnyh rasstrojstv* [Personality Disorders Diagnostic Questionnaire]. Moscow: Rech. [in Russian]

Egorov, A.Y., Krupitsky, Evgeny M., Sofronov A.G., Bobrov A.E., Tyavokina E.Y. & Dobrovolskaya A.E. (2013). Zloupotrebleniye alkogolem u bol'nykh, ekstremno gositalizirovannykh v bol'nitsu skoroy pomoshchi [Alcohol consumption in the patients of somatic hospital]. *Obozrenie psikiatrii i meditsinskoj psikhologii*. 1, 36–43. [in Russian].

Goulding, Robert & Goulding, Mary. (1979) *Changing lives through Redecision Therapy*. New York: Grove Press.

Hoyt, Michael F. (1989) Psychodiagnosis of personality disorders. *Transactional Analysis Journal*. 19:2, 101–113.

Hyer, Steven E. (1994). PDQ-4+ Personality Diagnostic Questionnaire-4+. New York, NY: New York State Psychiatric Institute.

Jiménez-Arriero, Miguel Ángel, Hernández, Belén, Mearin Manrique, Ignacio; Rodríguez-Jiménez, Roberto; Jiménez Giménez, Mónica; Ponce Alfaro, Guillermo. (2007). Celopatía alcohólica: un antiguo y actual dilema [Alcoholic jealousy: an old and current dilemma]. *Adicciones*. 19:3, 267-272. [in Spanish]

Joines, Vann. (1986). Using rededecision therapy with different personality adaptations. *Transactional Analysis Journal*. 16:3, 152–160.

Joines, Vann. (1988) Diagnosis and Treatment planning using a transactional analysis framework. *Transactional Analysis Journal*. 18:3, 185-190

Joines, Vann & Stewart, Ian. (2002). *Personality adaptations: A new guide to human understanding in psychotherapy and counseling*. Nottingham and Chapel Hill: Lifespace Publ.

Kocic, Sanja, Radovanovic, Snezana, Vasiljevic, Dragan, Milosavljevic, Mirjana, Djordjevic, Gordana & Zivanovic, Sandra. (2012). Sex as suicidal risk factor. *MED PREGLED*, 65:9-10, 415–420.

Larkin, Celine, Di Blasi, Zeldá & Arensman, Ella. (2014). Risk Factors for Repetition of Self-Harm: A Systematic Review of Prospective Hospital-Based Studies. *PLoS ONE*. 9:1, e84282. <http://www.ncbi.nlm.nih.gov/pmc/articles/PMC3896350/pdf/pone.0084282.pdf> accessed December, 2015.

Leonhard, Karl. (1968). *Accentuated Personalities [Akzentuierte Persönlichkeiten]*. Verl. Volk u. Gesundheit VEB.

Lichko, Andrey E. (1983) *Psichopatii i aktsentuatsii kharaktera u podrostkov* [Psychopathy and accentuations of character at teenagers]. Leningrad: Meditsina. [in Russian]

Magill, Molly & Ray, Lara A. (2009). Cognitive-behavioural treatment with adult alcohol and illicit drug users: a meta-analysis of randomized controlled trials. *J Stud Alcohol Drugs*. 70, 516-527.

McNeel, John. (1976). The Parent interview. *Transactional Analysis Journal*. 6:1, 61–68

- Meehan, Patrick J. (1990). Prevention: the endpoint of suicidology. *Mayo Clinic proceedings*. 65:1, 115–118.
- Menninger, Karl Augustus. (1938). *Man against himself*. New York, NY: Harcourt, Brace.
- Merinov, Alexei V. & Shustov, Dmitri I. (2012). Phenomen final'noj otkrytosti semejnoi sistemi v brakakh stradayushchikh alkohol'noj zavisimost'ju muzhchin [Phenomenon of the open final in the family systems of married men suffering from alcohol dependence]. *Zh Nevrol Psikhiatr Im S S Korsakova*. 112:10, 64-67. [in Russian]
- Mishra, Biswa R., Nizamie, S. Haque, Das, Basudeb & Praharaj, Samir K. (2010). Efficacy of repetitive transcranial magnetic stimulation in alcohol dependence: a sham-controlled study. *Addiction*. 105:1, 49-55.
- Najavits, Lisa M. (2013). Creating change: a new past-focused model for PTSD and substance abuse. In P. Ouimette & J. P. Read (Eds.), *Handbook of Trauma, PTSD and Substance Use Disorder Comorbidity*. Washington, DC: American Psychological Association Press.
- National Institute on Alcohol Abuse and Alcoholism. (2006). National epidemiologic survey on alcohol and related conditions. *Alcohol Alert*. 70. <http://pubs.niaaa.nih.gov/publications/AA70/AA70.pdf> accessed September 2015.
- National Institute on Drug Abuse. (2012). *Principles of drug addiction treatment: a research-based guide*. NIH Publication No. 12–4180.
- Niciu, Mark J. & Arias, Albert J. (2013). Targeted opioid receptor antagonists in the treatment of alcohol use disorders. *CNS Drugs*. 27:10, 777–787.
- Novikov, Sergey A. (2014). Alkogol'naja zavisimost' i projavleniya autoagressivnogo povedeniya u pacientov s razlichnymi tipami lichnosti [Alcohol dependence and self-destructiveness manifestations in patients with different personality types]. Candidate of Medical Science Thesis; Addiction Medicine. Moscow, National Research Centre for Addictions of the Ministry of Healthcare / Ryazan, Ryazan State Medical University.
- O'Farrell TJ, & Clements K. (2012) Review of outcome research on marital and family therapy in treatment for alcoholism. *J Marital Fam Ther*. 38(1),122-44.
- Osnes, Russel E. (1974). Spot Reparenting. *Transactional Analysis Journal*. 4:3, 40–46.
- Pompili, Maurizio, Serafini, Gianluca, Innamorati, Marco, Dominici, Giovanni, Ferracuti, Stefano, Kotzalidis, Giorgio D., Serra, Giulia, Girardi, Paolo, Janiri, Luigi, Tatarelli, Roberto, Sher, Leo & Lester, David. (2011). Suicidal Behaviour and Alcohol Abuse. *Int J Environ Res Public Health*. 7:4, 1392–1431.
- Preuss, Ulrich W., Koller, Gabriele, Barnow, Sven, Eikmeier, Markus, Soyka, Michael. (2006). Suicidal behavior in alcohol-dependent subjects: the role of personality disorders. *Alcohol Clin Exp Res*. 30:5, 866-877.
- Shustov, Dmitri I. (2000). *Autoagressivnoe povedenie i alkogolizm (Kliniko-terapevticheskoe issledovanie) [Self-destructive behaviour and alcoholism: clinical and therapeutic study]*: Doctor of Medical Science Thesis; Psychiatry, Addiction Medicine. Ryazan, Ryazan State Medical University. [in Russian]
- Shustov, Dmitri I. (2005). *Autoagressija, suicid i alkogolizm [Self-destructiveness, Suicide and Alcoholism]*. Moscow: Cogito-Center. [in Russian]
- Shustov, Dmitri I. (2009). *Rukovodstvo po klinicheskomu transaktnomu analizu [Handbook on Clinical Transactional Analysis]*. Moscow: Cogito-Center. [in Russian]
- Shustov, Dmitri I., Ivannikov, Yuri A. & Merinov, Alexei V. (1999). Ob otnoshenii bol'nykh alcogolizmom k faktoru ognia [On the attitude of patients with alcoholism to the factor of fire] *Pavlovskiye idei v razvitii sovremennoy nauki. Book of abstracts*. Ryazan: Ryazan State Medical University, 101-103. [in Russian].
- Shustov, Dmitri I., Merinov, Alexei V. & Tuchina, Olga. (2015). Episcrypt transmission in families of alcohol-dependent men: models and clinical observations. *Transactional Analysis Journal*. Published online before print. <http://tax.sagepub.com/content/early/2015/10/27/0362153715615120> accessed November, 2015.
- Shustov, Dmitri I., Merinov, Alexei V. & Valentik, Yuri V. (2000). *Diagnostika autoagressivnogo povedeniya pri alkogolizme metodom terapevticheskogo interv'ju [Diagnosing self-destructiveness in patients with alcohol dependence using therapeutic interview]*. Moscow: Ministry of Healthcare of the Russian Federation. [in Russian].
- Steiner, Claude. (1974). *Games alcoholics play: The analysis of life scripts*. New York, NY: Ballantine Books.
- Tilney, Tony. (1998). *Dictionary of Transactional Analysis*. London, Whurr Publishers Ltd.
- Ware, Paul. (1983). Personality adaptations (doors to therapy) *Transactional Analysis Journal*. 13:1, 11-19.
- Wedig, Michelle M., Silverman, Merav H., Frankenburg, Frances R., Reich, D. Bradford, Fitzmaurice, Garrett & Zanarini, Mary C. (2012). Predictors of suicide attempts in patients with borderline personality disorder over 16 years of prospective follow-up. *Psychol Med*. 42:11, 2395–2404.
- World Health Organization. (1992). *The ICD-10 classification of mental and behavioural disorders: Clinical descriptions and diagnostic guidelines*. Geneva, Switzerland: Author



## An Investigation using a Case Study Approach into the Impact on a Counselling Team in the UK of an Organisational Restructuring within a Family Support Service

© 2016 Gillian Robinson

### Abstract

*Following an organisational restructuring of a hospice in the UK, the author has used a case study approach to investigate the impact of this on a team of volunteer counsellors of which she was a member. A small number of the volunteer counsellors completed a questionnaire and some managers and other professionals were interviewed, and summaries of responses through each method are presented. The results are reviewed in terms of several transactional analysis concepts, and the author concludes by hypothesising that the impact of the restructuring on the counsellors appeared to parallel the sense of vulnerability felt by their clients.*

### Key words

hospice, transactional analysis, psychological distance, psychological games, discounting, group imago, case study

### Introduction

This investigation was undertaken within a hospice in the UK where an organisational restructuring had drawn together three areas of service user support which had worked in informal collaboration in the past: Chaplaincy, Bereavement Services and Admissions/Discharge. The all-encompassing department became Family Support Services, led by a Family Support Services Manager under the guidance of the Director for Patient Services.

The research focuses on the impact of the changes on the team of volunteer counsellors, of which the author was one. Prior to the restructuring, the counsellors had been led by a Bereavement Services Manager, who had been in post for more than six years; he was also a professional counsellor, so had extensive knowledge of counsellors' professional, ethical, training and support needs.

### Literature Review

#### The Hospice Movement

The model of the modern hospice movement in the UK and internationally was inspired by the work of Dame Cicely Saunders, whose vision was to move away from being sanctuaries run by religious orders for the dying poor and instead to emphasise palliative care. Dame Saunders "... devoted her life to making sure people could die with dignity and free from pain." (Richmond, 2005).

The hospice where this research was undertaken was established in 1992 and the following are references to some of the reports which influenced the restructuring.

Building on the Best (Department of Health 2003) concerned the UK Government pledge to give patients real choice rather than theoretical: in other words, choice would be made available through equality of access not only to those able to navigate the complex system but "we want choice, information and the power of personal preference extended to the many" (p. 3). The main challenges and changes were seen to be to give people a bigger say, particularly about the right to die where the individual wished, the right to die with dignity in one's own home, an increased choice of access to a wider range of services in primary care, and for individuals to have more information about the progress of their treatment and care. The report stated "Real change will happen at the front line, with support from the centre, fuelled by encouragement and expectation from patients and drawing on the experience of partner organisations and other experts." (p. 55)

This was followed by a NICE (National Institute for Clinical Excellence) (2004) report on supportive and palliative care for adults with cancer, in which it was



highlighted that "... patients want to be treated as individuals, with dignity and respect, and to have their voices heard in decisions about treatment and care." (p. 3). Through a National Cancer Patient Survey, it had been identified that there were geographic variations in the delivery of service so a service model was defined that emphasised assessing the need of the patient at the specific time in treatment, and recognition that some would need additional support. It was recommended that information regarding the availability of support should be made available to families and carers quite separately from information regarding the patient's treatment and care.

In a House of Commons Health Committee report (2004) it stated that, whereas 56% of people died in hospital, 20% at home, 20% in nursing or residential homes and 4% in hospitals, research indicated that the majority would choose to die at home. There was, however, an implication about the quality of care required by the dying and it was stated that "The right to a "good death" should be fundamental." (p. 38). More recently, Hughes-Hallett, Craft & Davies (2011) acknowledged that, whilst "We want to ensure everyone is able to live well until they die ...the current system is confusing and does not help people get the care and support they need, or provide them with meaningful choice" (p. 6).

Throughout the literature, there were consistent themes: to hear patients and put their wants and needs at the centre; to provide clarity and ease of use, so patients can make informed decisions; to ensure that families and carers are offered timely, appropriate support and information over and above that which is provided for patients, and that support continues in bereavement when necessary. To achieve these aims, there is acknowledgement throughout of the need for transparency, effective communication, engagement and involvement at all levels (including patients) and clarity of vision. The restructuring at the hospice had been undertaken in line with these themes, although it will be seen below that some of the fundamentals had been overlooked when it came to the service providers, including clarity of vision, effective communication, engagement and involvement.

### Transactional analysis

Transactional analysis concepts that appeared to be particularly relevant to the research in question included the three-cornered contract by English (1975), for which she highlighted the importance of clarity in the agreement between the organisation and other parties, and its development into psychological distancing by Micholt (1992). Micholt defines psychological distance as "a subjective measure, of sociometric origin, as experienced by each person." (p. 228) and comments that "[when] the distance between the three parties is perceived as equal. The contracts and expectations are clear on all sides, and there are clear role definitions for everyone. This is the ideal situation, in that it implies that all partners are open, willing to collaborate, and have no

hidden agendas, certainly a worthy goal." (p.229). She also points out that sometimes "the facilitator identifies with the participants (and not with the Great Powers), who are from similar social, cultural or professional backgrounds." (p. 231) and explains that with this particular imbalance may be demonstrated by We're OK, They're not OK or We're not OK, They're not OK behaviours.

Micholt also suggests that "... one of the consequences [of lack of balanced psychological distances] is the occurrence of games." (p.231). Hence, Karpman's (1968) drama triangle was also likely to be useful in understanding how the roles of Persecutor, Rescuer and Victim might be being played out within the team and their management. Micholt suggests that this can be avoided "... by working with participants and the Great Powers on role definitions, problem definitions and mutual expectations (group imago exercises, identifying Parent or Child projections). This might include teaching parties how to negotiate with one another." (p. 233) As an extension of this, Summerton (1992) provides the game pentagon, which he describes as a model that "... was based on a systems approach to the relationship knots that occur in organisations so that players could begin to recognize their part in the whole event without feeling accused of playing psychological games." (p.67). This emphasis by Summerton on the roles having both "... negative and positive connotations [so that] groups such as families can enjoy playing these roles while analysing many handy games..." (p.74) meant that it was likely to become a useful model to use for this study.

The concept of discounting was also likely to be relevant, including Schiff & Contributors' (1975) levels of T2: significance of stimulus, existence of problem and T3: possibility to change the stimulus, significance of problem, existence of options. Similarly, Berne's (1963) concept of the group imago as "The private structure, that is, the group as seen through the eyes of each member, in the group imago of the member. This private structure is the most decisive structural aspect for the outcome of the individual's therapy." (p. 153) can readily be converted from a therapeutic perspective to that of an organisational group. Clarkson (1991) went on to suggest that at a time of change, a group "... will usually regress to an earlier and less developed level of functioning and the group supervisor may need to help the group recycle through the various phases again." (p. 38). Because the group leader in this study had previously been the team's line manager, it was possible that this might occur and would be an unhealthy position for him to be drawn into; of relevance is Clarkson's suggestion that "Leaders cannot responsibly avoid being leaders if that is the psychological need of the group in its initial phase, just as parents cannot abdicate all structuring and decision-making to an infant without endangering it." (p. 40). There was, therefore, a danger that the counsellors might believe that one person was their manager, but would go elsewhere for guidance.



## Objectives/hypotheses

This study began as an open investigation to explore the impact of an organisational restructuring on a team of volunteer counsellors. As such, there was no formal research question beyond an exploration.

As a result of the information obtained via questionnaires and interviews, a concluding hypothesis is that the outcomes of the organisational restructuring have paralleled in some way the dynamics experienced by the clients of the hospice.

This is a small case study only so the outcome can only be regarded as tentative, but the methodology might usefully be copied to investigate similar organisational changes where the results might parallel client dynamics.

## Methodology

This research was conducted as a naturalistic study with a convenience sample. This method was chosen because the investigation was to be conducted within one organisational setting and with a limited number of participants, so that case study methodology seemed most appropriate. Widdowson (2011) has written extensively about case study research in line with McLeod's (2010) recommendations for this within counselling and psychotherapy, but the particular style applied by Widdowson refers to individual client cases so was not directly appropriate.

Hyett, Kenny & Dickson-Swift (2014) comment usefully, after this research had been conducted, that case study research is increasingly popular but differences in the ways in which such research is being conducted make it difficult to define it as a consistent methodology. They propose that it should be "an investigation and analysis of a single or collective case, intended to capture complexity of the object of study" (# 2). They reviewed 34 case studies against a checklist of criteria relating to the quality of the work which they had based on material by Stake (1995), Merriam (2009) and Creswell (2013). They commented particularly on: how a focus on outcomes often resulted in a case study report rather than a case study; how they found case studies in the health and social science categories without any explicit argument for why a case had been selected and a lack of attention to the limitations of a convenience sample; how adequate contextual description is required to understand the setting or context; and the way in which researcher and case interactions are a defining feature of case study methodology.

The case study reported here avoids the risk of being focused on outcomes; it is a convenience sample selected because the researcher was already there so the limitations of this are addressed below; it has been possible to provide the contextual description; and it has also been possible to comment on the role and position of the researcher, although the lack of triangulation is also addressed below as a limitation.

## Ethical Considerations

The research was done as part of studies towards a degree in Humanistic Transactional Analysis Counselling, with permission from the Hospice Management and approval from the Academic Ethics Committee of the University to carry out the research.

A Questionnaire Consent Proforma was used that included the comment that the results would be confidential and that participant anonymity would be preserved at all times. It also advised them that they had the right to withdraw from the survey at a later date, and asked them to sign that they gave their written permission for their responses to be used anonymously within the research. Similar statements appeared on the Interview Consent Proforma.

Employing questionnaires with a separate consent form offered participants a degree of anonymity; this felt appropriate as there was a sense of uncertainty and anxiety around the team at that time. It was this level of scare which led to a redesign of the questionnaire and an offer for completion on a second occasion, as will be explained below.

## Organisation, participants and researcher

As stated above, the hospice in which this research took place was established in 1992 and had recently been restructured. It is a registered charity offering free care for patients with life limiting illness and support to their families and carers. It has over 750 volunteers in addition to around 110 employees. There are currently 11 volunteer counsellors, down from 18 in 2011, one of the team had died in 2012 and some had left at the time of the resignation of the former Bereavement Services Manager, perhaps also prompted by the restructuring.

Two of the volunteer counsellors completed Version 1 of the questionnaire and seven completed Version 2. Of those seven, two were qualified and five were trainees. One had 18 months service, four had 2 years' and 2 had 5 years' service in the hospice. Two were male and 5 were female, and their ages ranged fairly evenly from 35 to 65 years.

Semi-structured interviews were conducted by the researcher/author with the Family Support Service Manager (18 years service), the Administrator (2.5 years service), the Counselling Psychologist (3 months service) and the Supervisor of the counsellors (11 months service). Questions were emailed to the Volunteer Services Manager (12 years service).

As researcher/author, I comment here also on myself as researcher because I am one of the volunteer counsellors at the hospice. The restructuring has impacted me personally and I have first-hand experience of the impact on others, as I have witnessed it. Throughout the research I have sought to remain aware of my own biases and prejudices. As I have reflected and been reflexive during the process, I have aimed to

present a balanced and ethical piece of research. Where I am aware of my biases and prejudices. I have owned the view to minimise the impact on this research paper.

### Questionnaires

The content of the final questionnaire can be seen in Table 1.

The participant group was not large enough to produce meaningful quantitative data so this research has been conducted using a qualitative approach. The first questionnaire used consisted of a series of questions, some of which could be answered by factual information, but others which required opinions, e.g. What is your understanding of the progress of the changes?

Only two of the 11 participants invited submitted a completed questionnaire and it seemed that the anxiety and tension observed during team meetings might be linked to this lack of response. A second version was therefore designed, in which were provided a range of strongly agree to strongly disagree responses to statements that closely resembled the questions of the original questionnaire.

Seven completed Version 2 questionnaires were received, which was disappointing as informal conversations and small group discussions had indicated that the counsellors had strong feelings about the changes and the lack of understanding of the needs of the counsellors working in this setting.

However, 7 questionnaires represents 67% of the team, and analysis of some of the questions within it demonstrated that it covered a mix of length of experience, whether qualified or in training, and experience of the organisation prior, since and during the restructuring. The second version was handed out during a meeting and the rate of response may well have been affected by the Director of Patient Services offering support for the research at that meeting.

### Interviews

Semi-structured interviews were used so that each interviewee was asked the same questions, and in order to be able to summarise responses and hopefully identify themes. The interviews were recorded and transcribed. Participants were questioned about:

- their understanding of the rationale for the restructuring;
- their views on the impact for various groups e.g. service users, volunteer counsellors, employees;
- the anticipated 'life span' of a volunteer and of a volunteer counsellor;
- their opinion about the style of the organisation, for which they were invited to choose from: Hierarchical, Parental, Consultative, Participative, Persuasive, Democratic, Autocratic or Chaotic;

- their personal experience of the restructuring, including anything they might have done differently with hindsight, and what further changes they believed necessary.

## Results

### Questionnaire Results

The responses to the Version 2 questionnaires are shown in Table 1. A final question was asked about how long participants planned to continue as volunteer counsellors within the hospice: two said they were considering leaving within the year and five said they had no plans to leave.

It is clear from the responses that the counsellors did not feel there had been clear communication of the rationale for the transition from being a bereavement service to being part of the Family Support Service. However, they did feel that they had had the opportunity to offer their opinions and give feedback, and that they had been heard because although their opinions were not sought prior to restructuring, their concerns and professional needs (supervision and training) were heard and acted on after the restructuring.

The consensus was that the transition had an impact on the counsellors, although not on their clients. This statements around the understanding of the role of the counsellors being understood by the organisation and management were evenly divided and this might have been impacted by individual counsellor's abilities to express their needs to others.

The feedback was unanimous about the supervisor understanding the counsellor's role, which is hardly surprising as the supervisor was a professional counsellor and a member of the same professional body as the team members. Although the team were split on a sense of belonging to the volunteer team at the hospice, they appeared to indicate a strong sense of identity as a team of counsellors. They recognised generally that their manager is the Family Support Service Manager (although one agreed yet wrote on the form that they did not know who their manager was), but said they would contact the Counselling Supervisor for guidance and support. This Supervisor is there for this when it is of a clinical nature, but it seems there is a lack of clarity around operational support.

There was a clear message from the counsellors that they did not feel supported prior to the changes; the opportunity had been missed to share the rationale and reporting mechanism with the team in advance of the restructuring.

### Interview Results

The responses during the semi-structured interviews are summarised in Table 2. There was a general view that the restructuring was aimed at consolidating the services offered to patients, families and carers. It was suggested that the Bereavement Service had been operating in

Question	Strongly Disagree	Disagree	Agree	Strongly Agree
Rationale for restructuring clearly communicated	4	2	1	
Restructuring had an impact on me		1	5	1
Restructuring had an impact on my client		6	1	
I feel my role as counsellor is understood by the organisation		4	3	
I feel my role as counsellor is understood by the Management		3	4	
I feel my role as counsellor is understood by the Supervisor			3	4
I feel my role as counsellor is understood by the the other counsellors		1	1	5
I feel I belong to the volunteer team		4	3	
I feel I belong to the counselling team		1	6	
The Family Support Service Manager is line manager of the counsellors (1 don't know)			6	
For guidance I would contact the Family Support Service Manager		4	2	1
For guidance I would contact the Counselling Supervisor	1	6		
I have had the opportunity to offer my opinion and/or feedback		1	6	
I feel that feedback from volunteer counsellors has been heard		2	5	
I felt supported and cared for prior to the changes by the organisation	2	3	2	
I felt supported and cared for prior to the changes by the Management	2	3	1	
I felt supported and cared for prior to the changes by the Supervisor	1	3	1	2
I felt supported and cared for prior to the changes by the other Counsellors		1	5	1
I feel supported and cared for now by the organisation		4	3	
I feel supported and cared for now by the Management		3	4	
I feel supported and cared for now by the Supervisor			7	
I feel supported and cared for now by the other counsellors			7	

*Table 1: Questionnaire Responses*

Questions	Summary of Responses
Understanding of the rationale for the restructuring	Several comments about bringing the service back into the organisation, avoiding isolation, using skills and expertise more for clients.  1 comment of "not privy to the rationale"
Impact on service users	2 comments on better quality of service; others said no impact
Impact on volunteer counsellors	Comments about not being looked after, left in a vulnerable place with no structure, hearsay, unease and anxiety, lack of clarity and a stressful vacuum; also that some had used the change as a vehicle for moving on
Impact on volunteer services	2 commented on confusion about who is who but others said little or no impact
Impact on employees	Huge learning curve, no handover, chaotic, lack of clarity; 1 said no effect as those joining are new positions
Anticipated 'life span' of a volunteer	All seem to stay a long time; there is a waiting list
Anticipated 'lifespan.' of a volunteer counsellor	Counsellors stay a long time, five years could be average, counsellors come on placement and stay when qualified
Style of organisation	3 said Hierarchical, also autocratic, chaotic
In hindsight, is there anything you would have done differently	Thought through transition beforehand, more transparency to limit anxiety, more participation and communication, and understanding of counselling and counsellor needs
Further changes needed	Several comments about availability and continuity of supervision, also recognition and acknowledgement of efforts made

*Table 2: Interview Responses*

isolation and that the umbrella of Family Support Service would mean that service users had one starting place where their needs can be assessed and directed to appropriate experts. It was viewed that this would bring the hospice structure in line with that operated in other hospices, and also that services could then be monitored, managed and benchmarked more effectively.

## Discussion

### Contracting and Psychological Distances

Combining English's (1975) contracting ideas with Micholt's (1992) concept enables us to see that the contract was changed significantly and led to problems of psychological distance. Using a simple three-cornered contract, the parties of organisation, counsellor and Bereavement Services Manager had the latter changed to the Family Support Services Manager. Hence what might well have been a shortened psychological distance between the original manager and the counsellors risked becoming an elongated psychological distance between the counsellors and the new manager. In addition, it seems that the Clinical Supervisor now became another party to the contract, raising the likelihood that there would again be a shortened psychological distance between them and the counsellors which would reinforce the sense that there was an elongated psychological distance between counsellors and new manager. The general lack of information and consultation also meant that it was extremely likely that the counsellors would feel at a

considerable psychological distance from the organisation itself.

### Psychological Games

In terms of Karpman's (1968) drama triangle, the Management may be thought of as in the role of Persecutor and the Supervisor and Counsellor as being the Victim. The team of counsellors are stuck in this place and have been there since March 2012 when the Bereavement Services Manager left his post, and possibly even from the time he resigned (October 2011) and began to prepare to leave. Although the restructuring would inevitably bring the group back to these initial uncertain stages of group development it was still there a year later. This is unhealthy for the continuing success of the team and its membership. To move forward and eliminate the risks at both clinical and operational levels there need to be interventions to bring the contract back into a place of balance through clarity of vision and responsibilities.

Summerton's (1992) game pentagon has been useful when considering what might have been happening, is happening and could happen with the restructuring. It offers reflexivity to the organisational changes and I have in this instance considered from my biases as a team member, researcher and from the information I have gathered through the questionnaires and interviews. As with the drama triangle, which is a study of the individual's interpersonal transactions, the roles change as the transactions between those involved happen. The game pentagon is

therefore a study of the social interactions of the members of the group. However, the roles can be construed as furthering or hindering those involved and the organisation of which they are in the service. From the information gathered in this work I have considered the roles that have emerged prior to the restructuring, as it happened and now.

Back then, the Director of Patient Services was in the role of *Stage Manager*, the counsellors, Family Services Manager and Volunteer Service Manager were the *Spectators*. Those who had decided to leave or held positions that were redundant had a feel of shifting between *Saviour*, *Scapegoat* and *Sniper* depending whose view was being canvassed and how safe that person was feeling at the time.

As the changes became reality, Director of Patient Services continued in the role of Stage Manager, the counsellors' uncertainties and anxieties moved them towards being the Sniper as they began to offer their opinions, formally and informally. The Family Service Manager and Social Worker became Scapegoats and the former Bereavement Services Manager, now the counsellors' clinical supervisor, became the Saviour. However, as the responsibilities of his role had altered considerably and he could no longer offer the leadership he had previously, there remained the gap of who was the team's operational leader. As this continued and transactions have gone back and forth, the supervisor has been at risk of being cast in the role of Scapegoat and/or Sniper. However he has offered the counsellors clarity about his role and what he can and cannot offer the team.

18 months after the team's all-encompassing leader left, the team and service continue to function and the team has shrunk. The Director of Patient Services has left and the role of Stage Manager seems vacant. The communication is improved and is two way. There are plans being formed for recruitment, training and induction of additional qualified counsellors to boost the team's number. The Family Services Manager is acting Director Patient Services. The Clinical Psychologist and Social Worker are in situ and communicating with the counsellors. The team's clinical needs are taken care of as the supervisor's contract is more permanent. Procedures are emerging regarding length of work and assessment of client needs. However there are still gaps procedurally and responsibilities are not defined, nor is the direction of the counselling team's future within the family services. There is an opportunity for an individual or individuals to offer clarity of vision and a plan for addressing the gaps. As identified by Clarkson (1991) "The process by which the provisional group imago is changed is influenced by member's characteristics, but also by the leadership tasks and behaviours" (p. 39)

### Discounting

The possible existence of discounting at T2 and T3 (Schiff & Contributors 1975) was evidenced in the views of the counsellors, where they felt that the rationale for

change was not clearly communicated. This view is further supported by the group interviews – for instance in one interview the comment was made that there was *'a huge kind of vacuum and what people will do with that is try and fill the vacuum with what is going on and there has not really been any answers so that has been kind of stressful for people'*.

### Group imago

When considering the group imago in line with Berne's (1963) stages, we can look at the possibility of what may be happening rather than showing a particular individual's imago. When considering the distancing in terms of group imago, the *provisional imago* is usually the individual's first 'experience' of the group, holding the fantasy of how the group will be. In general this would be established before the initial meeting as a group. Self and the organisation are identified and the other members indicated by the undifferentiated slot, which in this case includes the supervisor. In the scenario at the hospice it is unusual to find a developed team back at this initial stage; however the restructure caused the group to return to this early developmental stage. Clarkson (1991) suggested that a group may regress and need the leader to help the group, but I perceive the supervisor as being with the counsellors in this 'general' imago, albeit in an altered role. Being seen as undifferentiated from the counsellors is an unhealthy position for him to be drawn into and I believe creates further distancing from the organisation. It may be that this lack of differentiated state is as a result of the groups needs but this will remain a risk for the team, organisation, management and supervisor while roles and responsibilities remain undefined; it appears that the decision on to whom to turn for guidance and support is being left to the counsellors' discretion. As Clarkson (1991) commented "Bad management of critical periods in a group's life may affect its future functioning just as ineffective parenting affects an individual's subsequent social and psychological development".(p.37)

Also commenting on the provisional stage, Berne (1963) said; "In this stage the leader's most important task is to deal with external group process and to define the major external and internal boundaries" (p. 55). The group has deficient internal boundaries with roles and responsibilities undefined, with the organisation and management excluded, suggesting the team and supervisor function in isolation.

### Limitations

An obvious limitation has been the numbers involved in this study; however it is hoped that it will demonstrate a way of investigating the impact of a restructuring within a relatively small organisation, and particularly of the usefulness of TA concepts in such an activity.

Another limitation, already mentioned, was that the researcher was also a member of the team being researched, and had experienced personally the events being investigated. This was mitigated to some extent by the fact that this study was completed under professional



supervision and was also reviewed by various members of the tutor team and assessors at the University where the author was undertaking her studies.

The convenience sample of organisation and participants was selected because the researcher was already there and needed to conduct research as part of her studies; this could be seen as a limitation in that it was done to produce an assignment rather than because the management of the organisation had requested any consultancy support. This has meant, in turn, that it may be seen as research for the sake of research, in that the events being investigated have already occurred and the findings cannot, therefore, influence what happens next in the short term. However, it is to be hoped that publication may lead to more attention being paid to the potential difficulties in any future restructurings within the hospice movement or indeed within the Health Service generally.

## Conclusion

This work has been a consideration of the impact for volunteer counsellors at a hospice as a result of restructuring. As I began the study, I believed that I would find there had been little impact. I believed that the counsellors and I were displaying a resistance to change. However, as I gathered information and opinions over the months, and as the restructuring continues to develop, I believe that my own view discounted the significance of the impact on the counsellors, staff, service users and patients.

From the literature review, the rationale for the restructuring becomes clearer. The Family Support Service would offer patients, families and carers an all-encompassing service, which in turn could be benchmarked and monitored against other hospices for funding and also compliance with government directives and policies. It also provided an opportunity for the skills of counsellors to be used more fully, with earlier intervention where appropriate.

However, the restructuring caused anxiety and uncertainty for the counsellors. They did not know what the future for the service was going to be or how they were to fit into the new structure. They no longer had their line manager and were therefore concerned about potential lack of understanding of and provision for their professional requirements such as clinical supervision and training.

I have been impacted by the parallel of the team's position in the hospice and that of the hospice within our society – both appear to be hidden. The existence and purposes are known, but it is not until the service, or a counsellor, is required, that the services provided are fully understood, valued and appreciated. The counsellors have been left in a vulnerable position without the operational support that they had previously; this is another parallel with the work they do with the bereft who are in a vulnerable place due to loss.

**Gillian Robinson** BA Hons Transactional Analysis Humanistic Counselling, is an Accredited Member of the British Association for Counselling and Psychotherapy, and can be contacted on [contact@gillianrobinsoncounselling.co.uk](mailto:contact@gillianrobinsoncounselling.co.uk)

## References

- Berne, E (1963) *Structure and Dynamics of Organizations and Groups* Philadelphia: Lippincott
- Clarkson, P. (1991) Group Imago and the Stages of Group Development *Transactional Analysis Journal* 21 (1):36-50.
- Creswell, J W (2013) *Qualitative inquiry and research design: Choosing among five approaches* (3<sup>rd</sup> ed) Thousand Oaks, CA: Sage
- Department of Health. (2003) *Building on the Best'* <http://www.official-documents.gov.uk/document/cm60/6079/6079> Accessed: 31 January 2013
- English, F. (1975) The Three-Cornered Contract *Transactional Analysis Journal* 5(4):383-384
- House of Commons Health Committee (2004) *Palliative Care* <http://www.publications.parliament.uk/pa/cm200304/cmselect/cmhealth/454/45403> Accessed: 31 January 2013
- Hughes-Hallett, T, Craft, Alan & Davies, Catherine. (2011) *'Palliative Care Funding Review: Final Report: Funding the Right Care and Support for Everyone'*. <http://palliativecarefunding.org.uk/PCFRFinalReport> Accessed: 31 January 201
- Hyett, N, Kenny, A & Dickson-Swift, V (2014) Methodology for method? A critical review of qualitative case study reports *International Journal of Qualitative Studies on Health and Well-being* 9: 23606 – <http://dx.doi.org/10.3402/qhw.v9.23606>
- Karpman, S. (1968) Fairy Tales and Script Drama Analysis *Transactional Analysis Journal* 9(26):39-43
- McLeod, John (2010) *Case Study Research* London: Sage Publications
- Merriam, S B (2009) *Qualitative research: A guide to design and implementation* (3<sup>rd</sup> ed) San Francisco: Jossey-Bass
- Micholt, N. (1992) Psychological Distance and Group Intervention *Transactional Analysis Journal* 22(4):228-233.
- National Institute for Clinical Excellence (2004) *'Improving Supportive and Palliative Care for Adults with Cancer* <http://www.nice.org.uk/nicemedia/live/10893/28816/28816> Accessed: 31 January 2013
- Richmond, Caroline (2005) *Dame Cicely Saunders* <http://www.ncbi.nlm.nih.gov/pmc/articles/PMC1179787/> accessed 19 June 2013
- Schiff, J & Contributors (1975) *Cathexis Reader: Transactional Analysis Treatment of Psychosis*, New York: Harper & Row Publishers Inc
- Stake, R E (1995) *The art of case study research* Thousand Oaks, CA: Sage
- Summerton, O. (1992) The Game Pentagon *Transactional Analysis Journal* 22(2):66-75
- Widdowson, Mark (2011) Case Study Methodology *International Journal of Transactional Analysis Research*, 2:1 25-34

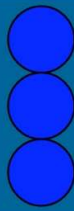

# The Many Faces of Transactional Analysis: A Survey Study of the Practice and Identity of Transactional Analysis Therapists in the UK

© 2016 Siobhan Gregory

## Abstract

*An online survey method was used with a sample of 99 therapists who had completed at least 4 years of transactional analysis psychotherapy training to investigate factors including their views on the most and least practised TA psychotherapy approaches based on the 'schools' of Classical, Redecision, Cathexis, Integrative, Psychodynamic and Relational. Demographic information on gender, age, therapeutic activity and professional associations was also collected, and the survey explored subjects' willingness to diversify their knowledge of therapies other than TA, how much they integrated across therapeutic modalities, and their commitment to a TA Identity.*

*Statistical analysis was conducted on the TA Identity and Integrative Identity scales within the survey, which were shown to have good reliability and internal consistency. Statistical analysis of results indicated that participants displayed significantly higher levels of Integrative Identity than TA Identity, although it was not clear whether that related to the TA Integrative approach or to the general integration of different approaches. Attainment of the international TA qualification as Certified Transactional Analyst (Psychotherapy) was shown to be related to commitment to TA and commitment in the TA community.*

## Key Words

schools of TA, transactional analysis psychotherapy, therapist identity, integrative psychotherapy, online survey

## Transactional Analysis Approaches

Transactional analysis (TA) benefits from a rich vein of theory, dating back to the nineteen fifties, which continues to evolve. The Classical school of TA is normally regarded as that based on Berne's (1961, 1966, 1972) original work, whereas the Redecision school

came somewhat later and consisted of combining TA with gestalt techniques so that clients could redecide script decisions in their Child ego state (Goulding & Goulding, 1979). At about the same time, the Cathexis school (Schiff & Contributors, 1975) took a more radical reparenting approach and paid close attention to transforming cognitive distortions. These three were followed by Integrative (Erskine & Trautmann, 1996; Erskine, Morsund & Trautmann, 1999) which integrated various fields of psychotherapy whilst placing empathy and attunement at the forefront of treatment in order to meet relational needs so that clients could integrate fixated ego states, and Psychodynamic (Novellino & Moiso, 1990; Moiso & Novellino, 2000) which followed the Freudian foundations of Berne's original theories, concentrating on transference to achieve psychoanalytic cure. The most recent addition has been Relational TA (Hargaden & Sills, 2002) which draws on a wide range of modern psychodynamic/psychoanalytic theory, concentrating on working with unconscious processes using various transferences in a therapeutic relationship where client and therapist fully participate.

We can consider the differences between the various schools or approaches by reference to Stark's (2000) descriptions of different psychologies. The role of the therapist within the classical, redecision, psychodynamic and some parts of the cathexis approach (correcting cognitive distortions) seems to embody what Stark described as a one-person psychology, where the therapist acts more as a neutral observer, providing interventions to increase client knowledge and move them out of psychopathology. The reparenting aspects of cathexis and the empathic attunement of integrative TA seem to reflect a one-and-a-half-person approach in which the therapist is equated to only half a person, hoping to effect change through empathy and mirroring whilst not giving away all of themselves. Relational TA

seems to embrace a two-person approach in which the therapist and client relate to each other as real people in a real relationship, mining the depths of their respective phenomenologies.

Just as TA has the potential to be practised in different modes, it may also resemble different theoretical orientations. A TA therapist choosing elements from the classical and cathexis schools may, for example, end up practising in a similar way to a cognitive-behavioural therapist; one employing integrative TA may practice in a similar way to a person-centred therapist; and the therapist embracing a relational TA approach with aspects of classical TA may appear to work in a similar way to a therapist employing a modern (pluralistic) psychodynamic approach to therapy.

Stewart (1996, 2000) advocates an approach which integrates elements of classical, redecision and cathexis TA. Clarkson (1992) also suggests an integrated approach to TA, combining classical, redecision and cathexis elements within a traditional psychodynamic/psychoanalytic standpoint.

## Literature Review

Although not related to TA, there have been previous quantitative research studies about aspects of therapists' practice. For example, Hollanders & McLeod (1999) carried out a postal survey of over 300 British counsellors in order to uncover their tendencies towards therapy integration, finding that whilst 42% classified themselves as integrative/eclectic, up to 87% displayed some degree of integration/eclecticism in their practice. Orlinsky, Ronnestad, Gerin, Willutski et al (1999) used extensive questionnaires to gather a great deal of multinational data across 20 countries on the development and practice of nearly 3800 therapists (55% female, average age 41 years), with the result that 54% displayed a tendency towards psychotherapy integration and did not identify with a single orientation. Cook, Biyanova, Elhai, Schnurr & Coyne (2010) conducted an internet survey with over 2000 therapists (77% female, average age of 59 years) to measure client base, theoretical orientation and technique preference, with the majority claiming to identify with more than one theoretical orientation or that they had an eclectic orientation.

In the UK, although some Integrative schools exist, psychotherapy is still predominantly taught by single orientation approaches (Cooper & McLeod, 2011). This is reflected at a higher level by health trusts and government initiatives favouring specific approaches (e.g. evidence-based CBT) and tailored treatments for specific conditions (Department of Health, 2001). This state of play creates an unfortunate sense of competition in the psychotherapy marketplace. Hollanders (2003) has pointed to the dangers of unproductive 'schoolism': in which 'binary thinking' therapists take an oppositional stance and defend the 'truth' of their own school. Norcross (2005) comments that "therapy systems, like battling siblings, competed for attention and affection in

a 'dogma eat dogma' environment (Larsen, 1980). Mutual antipathy and exchange of puerile insults between adherents of rival orientations were very much the order of the day." (p.3)

The existence of schoolism may be explained by cognitive dissonance theory (Festinger, 1957), when individuals, having invested in a particular choice, go on to feel more positively about and defend their original choice. Therapists who choose a particular orientation may have an investment in viewing it positively, in order to justify the time and energy they have invested in it (Cooper & McLeod, 2011).

Social identity theory offers another route through which schoolism may develop, with people feeling better about themselves if they can identify positively with the in-group to which they belong (Tajfel & Turner, 1979; Operario & Fiske, 2001; Dovidio & Gaertner, 2006; Cooper & McLeod, 2011). Larsson, Broberg & Kaldo (2013) investigated negative stereotyping, and found that those from CBT and psychodynamic backgrounds over-estimated the differences between themselves and therapists from other orientations; integrative/eclectic therapists were least likely to have stereotyped views of therapists from other orientations; and CBT therapists were the most likely to hold stereotyped views.

Norcross (2005) describes psychotherapy integration as an evolving movement that has gained considerable strength in the past 30 years. Integration is an antidote to and a reaction against entrenched schoolism, and a recognition that there are multiple routes to psychological health. Psychotherapy integration seeks to dissolve schoolism and has been brought about in part by therapists becoming disillusioned with the inadequacies of a single school approach (Garfield & Kurtz, 1977; Norcross, Karpiak & Lister, 2005).

As long as psychotherapy in the UK stays marked by divisions between different orientations, it seems that psychotherapy as a profession will be particularly vulnerable to schoolism. If, on the other hand, psychotherapists seek to embrace multiple orientations through integration/eclecticism, it seems they will be much less vulnerable to negatively judging fellow therapists on the basis of their chosen theoretical orientation (Larsson, Broberg & Kaldo, 2013).

Increasingly, there is an emphasis on a pluralistic framework, which can be seen as being governed by the client's own goals for therapy, the therapist's tasks or strategies and the methods employed. Inherent in the pluralistic approach to therapy is the idea that different therapies work for different people at different points – "collaborative pluralism can be regarded as an adaptation and elaboration of central themes found in other strategies for therapy integration". (McLeod, 2009 p.382), with the aim of developing "a way of practicing, researching and thinking about therapy which can embrace, as fully as possible, the whole range of

therapeutic methods and concepts.” (Cooper & McLeod, 2011 p. 6)

Widdowson (2013) argues that TA seems well placed to position itself as a pluralistic therapy. TA therapists already embrace openness and emphasise collaboration with their clients, and benefit from being well-versed in a variety of cognitive-behavioural, humanistic, psychodynamic and relational methods and techniques. “TA, as evidenced in the case series, both conceptualises the client and promotes change in cognitive, affective, behavioural and relational domains using an integrative and coherent framework. It would appear that this is a significant (and possibly) unique contribution that TA makes to psychotherapy.” (7.3.1.8)

## Research Question

The study was set up to gain a deeper understanding of how TA therapists practice. The practice and identity of them was of particular interest, as was the extent to which various TA approaches are embraced, rejected and/or integrated into practice. There was also an intention to ascertain if TA therapists saw their practice as similar to that of other theoretical orientations, and whether there was a tendency for therapy integration.

## Ethical Approval

This study was conducted under the auspices of an MSc program in Transactional Analysis Counselling provided by Physis Training, accredited by Queen Margaret University. Ethical approval was sought via a research proposal submitted to the MSc module leader (and University) who had overall authority for the program. Given that no clients were involved in the study and that there were no potentially sensitive or distressing survey questions, ethical approval was granted.

Survey respondents were not contacted directly and were completely anonymous. They could not withdraw once they had completed the survey but they could stop at any time during completion.

## Method

### Survey

An online questionnaire was devised, entitled Practice and Identity of TA Therapists, and powered by Survey Monkey ([www.surveymonkey.net](http://www.surveymonkey.net)). A pilot study of the survey was conducted with six colleagues, feedback was received and a preliminary analysis was carried out, after which some changes were made to produce the final version (see Table 2).

Timed to take less than five minutes to complete, the first page obtained information about respondents' age, gender, years of experience as a therapist, details of the amount, type and setting of their client work, their level of TA qualification and the professional associations of which they were a member. They were also asked to rank the six TA schools in order of importance and to state which they identified with most and least. The second page of the e-survey asked respondents to indicate the extent to which they agreed with 25 statements

pertaining to their practice and identity as TA therapists, using a 5 point Likert scale. The statements can be seen in Table 2.

Requests were made to all UK Association of Transactional Analysis (UKATA) registered training establishments to distribute the link to the e-survey to all previous psychotherapy trainees who had completed 4 years of TA psychotherapy training, which equated to Diploma level or above as awarded by the centres. Of these, Physis Training, Wealden Institute, Ellesmere Centre, Leeds Psychotherapy Training Institute, and the Link Centre did so. Metanoia Institute also circulated the survey, as did UKATA itself. The covering email assured respondents that all responses were entirely anonymous and confidential. The researcher's email address was given if they wished to ask any questions.

### Participants

The opportunistic sample of 99 comprised 67 females and 27 males, plus 5 who declined to indicate gender. Only 90 of those responded to all of the statements in the second half of the survey. The results indicated below are therefore based on 99 responses for the first section and 90 for the second.

In addition to having completed core transactional analysis psychotherapy training, some had obtained a master's level qualification in TA and some had attained Certified Transactional Analyst (Psychotherapy) (CTA) or Teaching & Supervising Transactional Analyst (Psychotherapy) (TSTA). All of them worked with individual clients, just over half worked with couples, and nearly a third did group work. The highest proportion of them had 1-10 year's experience and most practised 1-10 hours per week. The majority worked in private practice, with a small number doing voluntary or NHS work. This information about the sample is given in more detail below within the analysis of Results.

## Results

### Demographics

71.3% were female and 28.7% were male.

Figure 1 shows the age distribution; Figure 2 shows years of practice; and Figure 3 indicates the level of TA qualifications held. Figure 4 indicates the settings of practice and Figure 5 shows membership of professional associations. Figures 6 and 7 show respectively the TA approaches most and least identified with, whilst Figure 8 indicates the importance rankings given to the TA schools. Table 1 contains the raw data corresponding to Figure 8.

Note that for Figures 3, 4, 5 and 8, participants were able to select more than one response

*Editor's Note 1: n = 99 so demographic raw scores are virtually identical to percentages.*

*Editor's Note 2: in Figure 5, members of ITA/UKATA are automatically members of EATA, so EATA membership must apply to at least 90 respondents.*



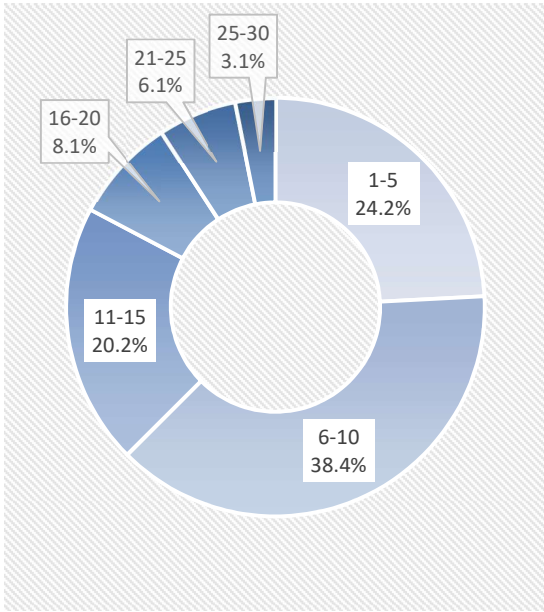

Figure 1: Age Distribution

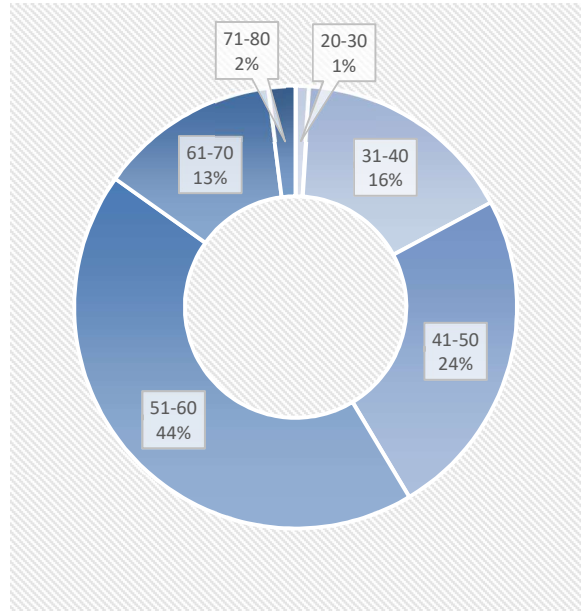

Figure 2: Years of Practice

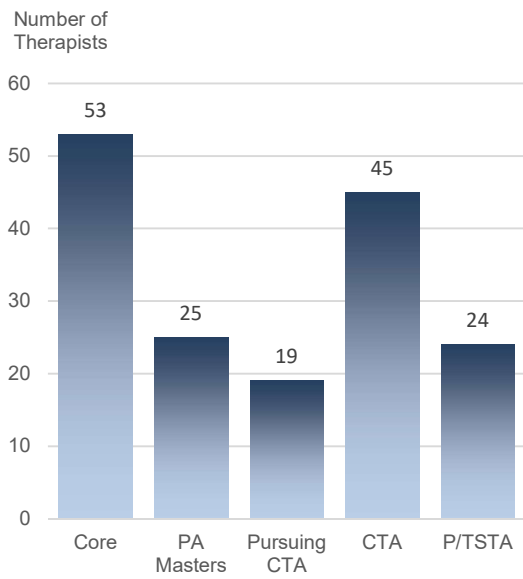

Figure 3: Level of TA Qualification

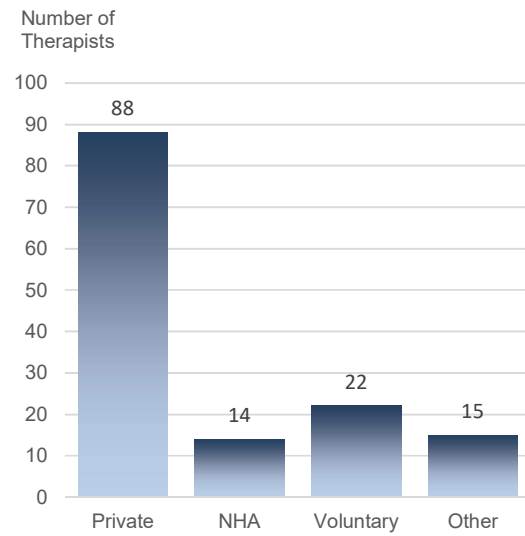
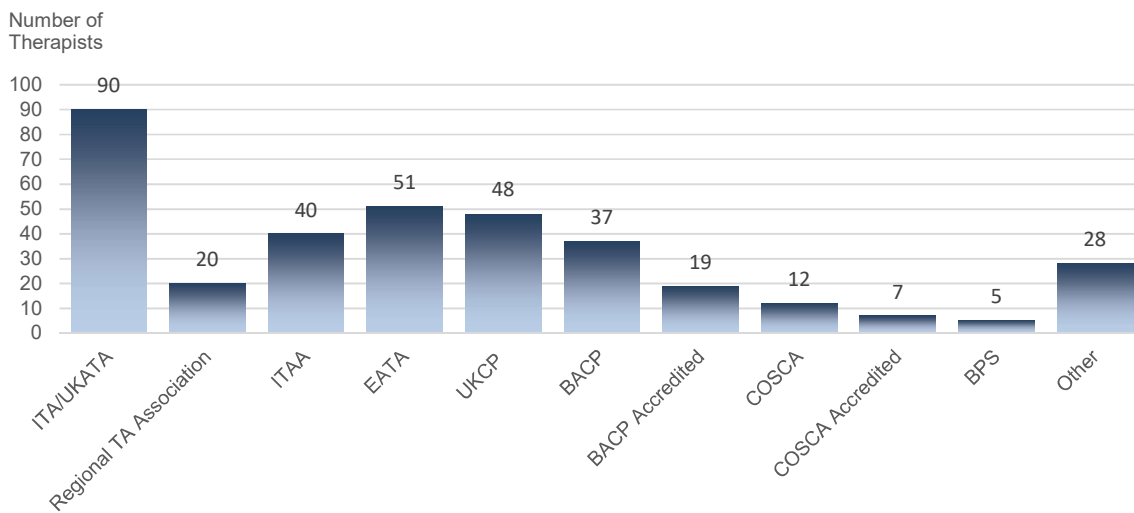

Figure 4: Setting of Therapy Practice





ITA/UKATA	Institute of Transactional Analysis/UK Association of Transactional Analysis
ITAA	International Transactional Analysis Association
EATA	European Association of Transactional Analysis
UKCP	UK Council for Psychotherapy
BACP	British Associations for Counselling & Psychotherapy
COSCA	Counselling & Psychotherapy in Scotland
BPS	British Psychological Society

Figure 5: Membership of Professional Associations

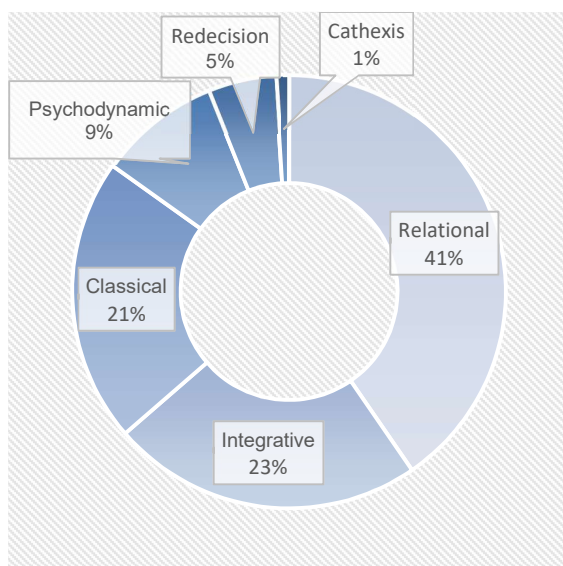

Figure 6: TA Approach **Most** Identified With

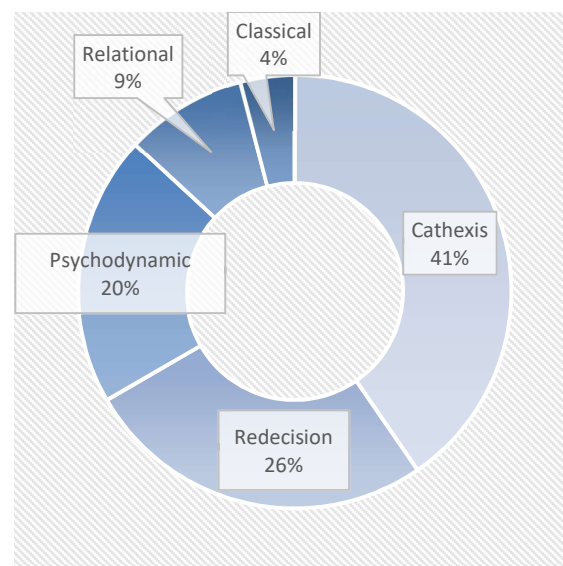

Figure 7: TA Approach **Least** Identified With

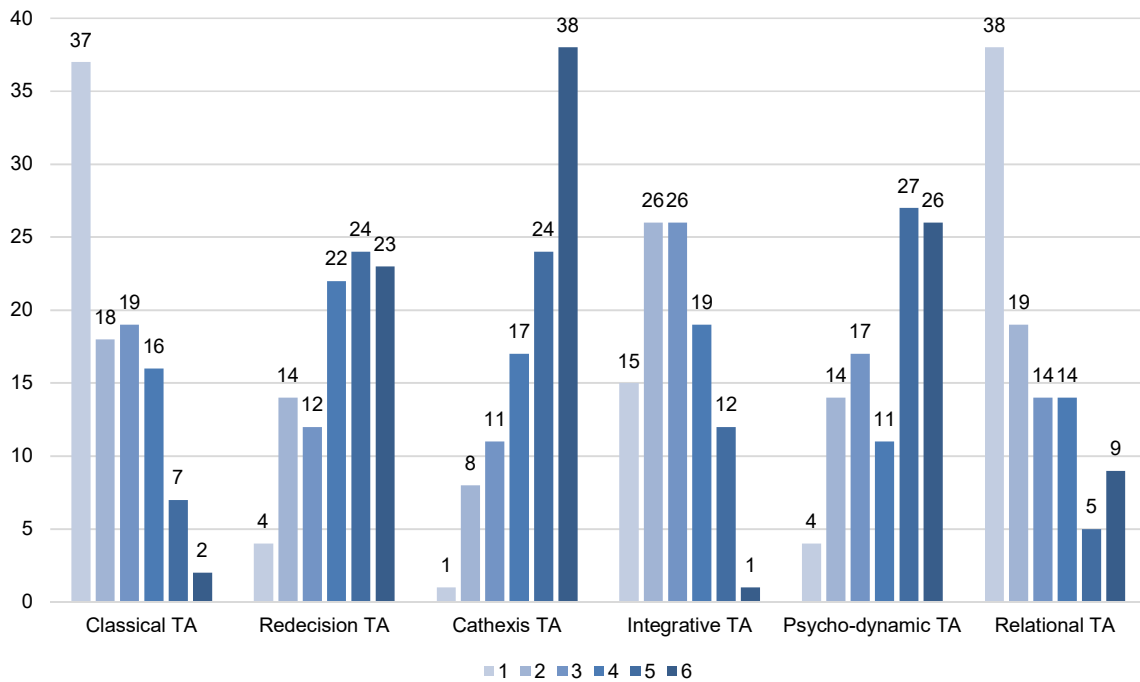

Figure 8: Ranking of TA Schools in Order of Importance

	1	2	3	4	5	6	Total
Classical TA	37.37%	18.18%	19.19%	16.16%	7.07%	2.02%	
	37	18	19	16	7	2	99
Redecision TA	4.04%	14.14%	12.12%	22.22%	24.24%	23.23%	
	4	14	12	22	24	23	99
Cathexis TA	1.01%	8.08%	11.11%	17.17%	24.24%	38.38%	
	1	8	11	17	24	38	99
Integrative TA	15.15%	26.26%	26.26%	19.19%	12.12%	1.01%	
	15	26	26	19	12	1	99
Psycho-dynamic TA	4.04%	14.14%	17.17%	11.11%	27.27%	26.26%	
	4	14	17	11	27	26	99
Relational TA	38.38%	19.19%	14.14%	14.14%	5.05%	9.09%	
	38	19	14	14	5	9	99

Table 1: Ranking of TA Schools in Order of Importance

## Practice and Identity

24 of the 25 statements in the second part of the survey have been clustered into four categories for the purposes of presentation in Table 2: these are TA Practice, TA Identity, Integrative Identity, and Approach Similarities.

In the **TA Practice** category, the majority of participants (85.8%) said they did not rely on just one TA approach. 48.4% disagreed and 37.4% strongly disagreed with the statement 'I rely on the theory and technique of one particular approach to TA.' Only one person (1.1%) agreed with this statement. Similarly, nearly all the participants (95.7%) agreed that they relied on a variety of techniques drawn from different approaches to TA. The majority (92.4%) also thought of TA as an integrative therapy and 72.4% actively attempted to integrate competing TA theories in their practice.

Responses to statements about **TA Identity** received a mixed response. It can be seen that participation in the TA community was important to the majority (73.7%) of participants and 87.8% had attempted to deepen their TA knowledge since completing their training. However, statements regarding Continuing Professional Development (CPD) activity showed there was no clear preference for or against CPD activities with a specific TA content and orientation. Roughly equal numbers agreed, disagreed or were neutral about having a preference for specifically TA orientated reading material, workshops, CPD activities or conferences.

When it came to responses in the **Integrative Identity** category, a strong tendency towards therapy integration was displayed. Overall, the vast majority (93.5%) thought it was important to have a broad knowledge of theories and techniques from other therapeutic modalities. In addition, 87.9% had attempted to integrate techniques and theories from other therapeutic modalities in their practice with clients. Likewise, 83.3% had attempted to diversify their knowledge of other therapies since completing their TA training and 60.5% felt they had to look outside of TA to fully help their clients.

There was very little disagreement with statements regarding a preference for general CPD activities. Most participants (61.6%) endorsed reading books and journals with a general approach to therapy. Similarly, 72.5% said they would prefer to attend activities or workshops with a diverse approach to therapy. There was some uncertainty over preferences for conferences aimed at counsellors/therapists in general; 44.5% agreed they preferred these but more (46.7%) had a neutral response. There was also a mixed response to the statement 'My commitment to the TA approach to therapy has declined since completing my core training.' Whilst the majority (55%) disagreed with this statement, 31.9% agreed with it and 13.2% had a neutral response.

When it came to statements regarding TA's **similarities to other approaches**, the clear majority (90%) felt that their way of working shared many similarities with a

humanistic approach to therapy. Likewise, 85.7% felt that their way of working shared many similarities with an integrative/eclectic approach to therapy. There was no disagreement with either of these statements. Participants had less certainty that their way of working with clients shared many similarities with a CBT approach; only 2.2% strongly agreed with this statement and 35.6% agreed, 26.7% had a neutral response, 28.9% disagreed and 6.7% disagreed strongly. Participants had slightly more agreement (55% overall) that their way of working shared many similarities with a psychodynamic approach to therapy, 31.9% had a neutral response and 13.2% overall disagreed.

## Statistical Analysis

As previously mentioned, only 90 participants responded to all statements. Given that a minimum of 100 participants are needed for factor analysis, it could not be carried out in the present study. Had there been a larger sample, it would have been optimal to use this tool to test for underlying dimensions measured by the statement questions. As an alternative to this, the four statement categories in Table 2 underwent reliability analysis using Cronbach's Alpha. It was found that the 8 statements in the TA Identity category correlated well with one another, showing good internal consistency and reliability with a high alpha of 0.87. The 8 statements can be said to effectively measure TA Identity and give credibility to TA Identity being a reliable subscale. There was a similar result for the 8 items in the Integrative Identity category, showing it to be a reliable subscale. This subscale originally contained 9 statements but it was shown that a higher alpha of 0.79 could be obtained if the statement 'Participation in the wider therapy community is important to me.' was deleted.

On average, participants' mean Integrative Identity scores ( $M = 3.74$ ,  $SD = 0.51$ ) were higher than their mean TA Identity scores ( $M = 3.28$ ,  $SD = 0.60$ ). A paired samples t-test was carried out to test if these differences were significant. The results ( $t(90) = 4.31$ ,  $p = 0.00$ , 2-tailed) confirmed that participants displayed significantly higher levels of Integrative Identity than TA Identity.

To investigate whether differences in therapy identity were tempered by level of TA qualification, a number of independent samples t-tests were carried out. These looked at whether having CTA had any bearing on various aspects of TA/Integrative Identity. It was found that on average, participants with CTA ( $M = 4.2$ ,  $SD = 0.72$ ) had greater agreement with the statement 'I am committed to the TA approach to therapy.' than those without CTA ( $M = 3.88$ ,  $SD = 0.71$ ). An independent samples t-test confirmed that participants who had attained CTA showed significantly higher levels of commitment to the TA approach to therapy than those who had not ( $t(89) = 2.099$ ,  $p = 0.039$ , 2-tailed).

Participants with CTA also seemed to agree more ( $M = 4.41$ ,  $SD = 0.68$ ) than participants without CTA ( $M = 3.90$ ,  $SD = 0.76$ ) that they had attempted to deepen their TA

Statement category	Statement	Strongly Agree	Agree	Neutral	Disagree	Strongly Disagree	Total responses
TA Therapy Integration	12. 'I rely on the theory and technique of one particular approach to TA.'	0% (0)	1.1% (1)	13.2% (12)	48.4% (44)	37.4% (34)	91
	13. 'I rely on a variety of techniques from different approaches to TA.'	51.7% (47)	44% (40)	2.2% (2)	1.1% (1)	1.1% (1)	91
	14. 'I try to integrate competing TA theories.'	19.8% (18)	55% (50)	22% (20)	3.3% (3)	0% (0)	91
	21. 'I think TA is an integrative therapy.'	37.4% (34)	55% (50)	5.5% (5)	2.2% (2)	0% (0)	91
TA Identity	22. 'TA is all I need to help my clients.'	2.2% (2)	5.5% (5)	17.8% (16)	56.7% (51)	17.8% (16)	90
	24. 'I am committed to a TA approach to therapy.'	24.2% (22)	56% (51)	16.5% (15)	3.3% (3)	0% (0)	91
	26. 'I prefer to read books and journal articles that are specifically related to TA.'	1.1% (1)	21.1% (19)	34.4% (31)	34.4% (31)	8.9% (8)	90
	28. 'I prefer to attend CPD's or workshops that are led by trainers with a TA approach to therapy.'	2.2% (2)	33.3% (30)	30% (27)	33.3% (30)	1.1% (1)	90
	29. 'I prefer to attend CPD's or workshops that specifically relate to a TA approach to therapy.'	1.1% (1)	27.8% (25)	32.2% (29)	35.6% (32)	3.3% (3)	90
	31. 'I prefer to attend conferences that are specifically aimed at TA therapists.'	7.7% (7)	39.6% (36)	28.6% (26)	20.9% (19)	3.3% (3)	91
	33. 'Since completing my core TA training I have attempted to deepen my knowledge of TA.'	30% (27)	57.8% (52)	6.7% (6)	5.6% (5)	0% (0)	90
	36. 'Participation in the TA community is important to me.'	20.9% (19)	52.8% (48)	22% (20)	3.3% (3)	1.1% (1)	91
Integrative Identity	15. 'In my work with clients, I try to integrate theories and techniques from other therapeutic modalities.'	28.6% (26)	59.3% (54)	9.9% (9)	2.2% (2)	0% (0)	91
	20. 'I think it is important to have a broad knowledge of techniques and theories from different approaches to therapy.'	40.7% (37)	52.8% (48)	5.5% (5)	1.1% (1)	0% (0)	91

Statement category	Statement	Strongly Agree	Agree	Neutral	Disagree	Strongly Disagree	Total responses
	<b>23.</b> 'I need to look to approaches outside of TA to fully help my clients.'	18.7% (17)	41.8% (38)	26.4% (24)	12.1% (11)	1.1% (1)	91
	<b>25.</b> 'My commitment to the TA approach to therapy has declined since completing my core training.'	11% (11)	20.9% (19)	13.2% (12)	44% (40)	11% (10)	91
Integrative Identity	<b>27.</b> 'I prefer to read books and journal articles that are related to therapy in general.'	11% (10)	50.6% (46)	35.2% (32)	3.3% (3)	0% (0)	91
	<b>30.</b> 'I prefer to attend CPD's or workshops with a diverse approach to therapy.'	14.3% (13)	58.2% (53)	24.2% (22)	3.3% (3)	0% (0)	91
	<b>32.</b> 'I prefer to attend conferences that are aimed at counsellors or therapists in general.'	7.8% (7)	36.7% (33)	46.7% (42)	8.9% (8)	0% (0)	90
	<b>34.</b> 'Since completing my core training, I have attempted to diversify my knowledge of other therapies.'	31.1% (28)	52.2% (47)	13.3% (12)	3.3% (3)	0% (0)	90
Approach Similarities	<b>16.</b> 'My way of working with clients shares many similarities with a CBT approach to therapy.'	2.2% (2)	35.6% (32)	26.7% (24)	28.9% (26)	6.7% (6)	90
	<b>17.</b> 'My way of working with clients shares many similarities with a psychodynamic approach to therapy.'	8.8% (8)	46.2% (42)	31.9% (29)	12.1% (11)	1.1% (1)	91
	<b>18.</b> 'My way of working with clients shares many similarities with a humanistic approach to therapy.'	28.9% (26)	61.1% (55)	10% (9)	0% (0)	0% (0)	90
	<b>19.</b> 'My way of working with clients shares many similarities with an integrative/eclectic approach to therapy.'	29.7% (27)	56% (51)	14.3% (13)	0% (0)	0% (0)	91

*Table 2: Participants' agreement with categorised statements*



knowledge since completing their training. An independent samples t-test confirmed that participants with CTA displayed significantly more agreement than those without CTA ( $t(88) = 3.307, p = 0.001, 2\text{-tailed}$ ).

Within the Integrative Identity subscale, participants with CTA ( $M = 4.33, SD = 0.66$ ) seemed to show higher levels of agreement with the statement 'Since completing my core training, I have attempted to diversify my knowledge of other therapies.' than participants without CTA ( $M = 3.92, SD = 0.77$ ). An independent samples t-test confirmed that participants with CTA displayed significantly more agreement than those without CTA ( $t(88) = 2.667, p = 0.009, 2\text{-tailed}$ ).

Finally, it seemed that participants with CTA showed more agreement ( $M = 4.15, SD = 0.70$ ) than those without CTA ( $M = 3.75, SD = 0.74$ ) that participation in the TA community was important to them. An independent samples t-test confirmed that the differences were significant, showing that participation in the TA community was significantly more important to those who had attained CTA than those who had not ( $t(89) = 2.644, p = 0.01, 2\text{-tailed}$ ).

In order to investigate whether differences in mean TA Identity and Integrative Identity scores were tempered by participant's preferred TA approach, one-way ANOVAs were carried out. Participants were split into 6 groups on the basis of the TA approach they identified with most. It was found that mean Integrative Identity scores did not differ significantly across the 6 groups. Preferred TA approach did not seem to have a significant impact on mean Integrative Identity scores. In contrast, a one-way between subjects ANOVA revealed that participants' preferred TA approach did have an impact on mean TA Identity scores, as these scores differed significantly across the 6 groups:  $F(5,85) = 2.993, p = 0.015$ .

In order to investigate if there was an interactive relationship between CTA attainment, preferred TA approach and mean TA Identity, a 2-way between-subjects (2 x 6) ANOVA was carried out and no significant interactions were found. This shows that participants' preferred TA approach had a significant impact on their TA Identity irrespective of whether they had attained CTA or not.

Independent samples t-tests were carried out to investigate where exactly the differences in the 6 groups of preferred TA approach occurred. Mean TA Identity scores of participants preferring classical TA ( $M = 3.61, SD = 0.597$ ) seemed higher than those of participants preferring relational TA ( $M = 3.11, SD = 0.597$ ) and psychodynamic TA ( $M = 2.87, SD = 0.554$ ). Independent samples t-tests confirmed that participants who identified most with classical TA had significantly higher mean TA Identity scores than participants who identified most with relational TA ( $t(57) = 3.261, p = 0.002, 2\text{-tailed}$ ) and psychodynamic TA ( $t(26) = 3.269, p = 0.003, 2\text{-tailed}$ ) respectively. Therefore, various aspects of TA identity were significantly more important to participants who

preferred classical TA than participants who preferred relational TA or psychodynamic TA.

Looking more specifically at one particular aspect of TA Identity, commitment to TA, a one way ANOVA revealed there were significant differences across the 6 groups of preferred TA approach ( $F(5,85) = 3.301, p = 0.009$ ). As previously mentioned, significant differences in commitment to TA were found between participants who had and had not attained CTA. In order to investigate if there was an interactive relationship between CTA attainment, preferred TA approach and scores measuring TA commitment, a 2-way between-subjects (2 x 6) ANOVA's was carried out. The main effect of preferred TA approach was significant ( $F(5,80) = 2.968, p = 0.001$ ). The main effect of whether participants had attained CTA or not was very close but not significant at the  $p < 0.05$  level ( $F(1,80) = 3.641, p = 0.06$ ). There was no significant interaction between the factor of CTA attainment and preferred TA approach ( $F(4,80) = 0.885, p > 0.05$ ). This shows that participants' preferred TA approach had a significant impact on their commitment to TA irrespective of whether they had attained CTA or not.

Independent samples t-tests were carried out to investigate where exactly the differences in the 6 groups of preferred TA approach occurred. Mean scores measuring commitment to TA of participants preferring classical TA ( $M = 4.48, SD = 0.512$ ) seemed higher than those of participants preferring relational TA ( $M = 3.79, SD = 0.741$ ) and psychodynamic TA ( $M = 3.86, SD = 0.69$ ). Independent samples t-tests confirmed that participants who identified most with classical TA had significantly higher mean TA Identity scores than participants who identified most with relational TA ( $t(57) = 3.772, p = 0.00, 2\text{-tailed}$ ) and psychodynamic TA ( $t(26) = 2.542, p = 0.017, 2\text{-tailed}$ ) respectively. Therefore, participants who identified most with classical TA displayed significantly higher levels of commitment to TA than participants who identified most with relational TA and psychodynamic TA.

## Discussion

It was clear to see that some branches of TA were more popular than others. Relational TA was the TA approach that participants identified with most, with over 40% choosing it. Integrative TA was the second most popular TA approach, with 23.2% saying that they identified with this most. Integrative TA was closely followed by classical TA with 21.2% saying they preferred this approach. It is unclear here whether participants choosing integrative TA as their preferred approach were declaring their allegiance to Erskine's integrative TA, or whether they were showing a preference for integrating TA theories in a general way.

It was shown that participants' preferred TA approach had a bearing on the extent to which they identified with TA. For example, participants who identified most with classical TA displayed significantly higher levels of TA

Identity than participants who identified most with relational TA or psychodynamic TA.

The level of TA qualification reached had a bearing on TA identity. Commitment to TA was found to be significantly higher, with a greater tendency towards deepening their TA knowledge post-training, by those who had attained CTA. Participation in the TA community also seemed to be mediated by CTA attainment. However, the greatest predictor of TA Identity levels was TA approach preference. The fact that participants choosing classical TA had higher levels of commitment to TA and TA Identity might be attributed to classical TA being the more traditional or grassroots level of TA. It is possible that people with a preference for relational TA have their identity more invested in relational TA circles (there is a growing IARTA – International Association of Relational TA - membership). Alternatively, they may identify more as integrative therapists. Only one person chose cathexis TA as the approach they identified with most and over 40% chose it as the approach they identified with least. Redecision TA did not fare much better, with only 5% saying they identified with this approach most and 26.3% saying they identified least with this approach.

Encouragingly, the present study found that the TA therapists surveyed displayed high levels of psychotherapy integration. The therapists surveyed showed a tendency to integrate theories and techniques from competing schools within TA. Overwhelmingly, therapists rejected the idea of using one particular TA approach in their practice., and instead endorsed employing a variety of techniques and theories across multiple approaches to TA. General therapy integration was also endorsed and practiced by the vast majority, with about 85% believing their way of working shared many similarities with an integrative/eclectic approach to therapy. These results are compatible with the research reported above in terms of integrative/eclectic approaches (Hollanders & McLeod, 1999; Orlinsky et al, 1999; Cook et al, 2010; Norcross et al, 2005).

The endorsement of general psychotherapy integration was reflected in respondents' endorsement of CPD activities. With the exception of conferences, CPD activities which took a general/integrative approach were more readily endorsed than those that had a specific TA orientation. Indeed, when composite measures of Integrative Identity and TA Identity were taken, the therapists surveyed displayed significantly higher levels of Integrative Identity than TA Identity. Furthermore, whilst levels of TA Identity fluctuated significantly on the basis of preferred TA approach, Integrative Identity levels remained high regardless of participants' preferred TA approach. Once training has finished, there is perhaps a tendency to look outside of TA, to diversify knowledge. It may be important for therapists to immunise themselves against becoming isolated, stagnant practitioners. Varied CPD activities with varied practitioners can be rejuvenating and stimulate more thoughtful practice. The

present study's results suggest there is something universal about the tendency towards integration.

It is noteworthy that one group of participants who showed high levels of commitment to TA, participation in the TA community and high levels of general TA identity were those who had attained CTA. However, alongside this strong identification with TA, these participants (who had attained CTA) also showed a significantly higher tendency than those without CTA to diversify their knowledge of therapies outwith TA. This suggests that even those strongly identified with single orientation approaches are open to therapy integration. There is also a possibility that the popularity of relational TA is linked to the endorsement of integration. Relational TA is an approach that is forward facing and inherently integrative, acknowledging as it does the contributions of neuroscience, attachment research, object relations, ego psychology and self psychology.

## Limitations

Although the survey had a significant sample size, it was evident that respondents had attained different levels of TA qualifications and were therefore not homogeneous in this respect so the sample sizes for the different levels were correspondingly smaller. Designing the survey to ensure that it would not take too long to complete meant that more nuanced information on the intricacies of practice/identity could not be obtained.

Once the survey had been completed, it became clear that certain elements could have been improved upon. For example, when participants were asked to select which TA approach they identified with most it was unclear whether those selecting integrative TA were doing so because they identified with Erskine et al's (1999) brand of integrative TA. Participants may instead have been indicating a preference for integrating various TA theories and concepts in a general way. The same could be said of psychodynamic TA; participants may not have been indicating their preference for Novellino & Moiso's (1990) brand of TA. They may instead have been indicating a preference for practising TA in a similar way to modern psychodynamic therapy. In hindsight, this could have been avoided by putting the key authors associated with each TA approach in brackets beside the approach.

Another drawback of the survey was that the user interface for the question asking participants to rank the TA approaches in order of importance from 1 to 6 was quite clumsy and confusing for some participants. For around 20% of participants, their ranking of approaches did not match up to the approaches they said they identified with most/least. This meant that the data for this question was deemed unreliable and excluded from further analysis.

The author/researcher has herself undergone the TA training and processes of identification that were being explored in this study, which may of course have biased the design of the questionnaire and the interpretation of the results.

## Conclusion

Part of the motivation for the present study was to get a clearer idea of what TA therapy consists of, given the vast array of approaches, theories and techniques available to therapists, both within and outside TA. The majority of TA therapists in the survey believed their way of working was similar to an integrative approach to therapy. In addition to this, 90% felt their way of working was similar to a humanistic approach to therapy; 55% agreed their way of working shared many similarities with a psychodynamic approach; 37.8% said their way of working shared many similarities with a CBT approach.

These results suggest that most participants see TA as a humanistic therapy, consistent with its ethos that people are OK and capable of change. The fact that there was weaker support for therapists seeing their way of working as comparable to CBT may reflect a greater reliance on relational ways of working. Alternatively, for those therapists practicing classical TA, there may be some negative stereotyping of CBT occurring. There could also be an unwillingness to see the many commonalities between a classical TA and CBT approach.

In contrast to the relatively low levels of endorsement of commonalities between TA and CBT practice, the therapists surveyed seemed surer that their way of working shared many similarities with a psychodynamic approach to therapy. This may reflect the commonalities between psychodynamic therapy and TA, particularly for those practicing classical and relational TA. As previously mentioned, relational TA has harnessed many key theories and developments from the world of psychodynamic and psychoanalytic therapy.

It is hoped that others may wish to copy the methodology of this study in order to build up an ever more detailed understanding of the practice and identity of transactional analysis therapists. The use of an online survey makes it particularly easy to access significant samples of subjects, in a convenient and low-cost manner.

**Siobhan Gregory**, BSc (Hons) Psych, MSc Transactional Analysis Counselling can be contacted on [staufercat@hotmail.com](mailto:staufercat@hotmail.com)

## References

Berne, E. (1961) *Transactional Analysis in Psychotherapy*. New York: Grove Press

Berne, E. (1966) *Principles of Group Treatment*. Menlo Park: CA

Berne, E. (1972) *What Do You Say After You Say Hello?* London: Corgi.

Clarkson, P. (1992). *Transactional Analysis Psychotherapy: An Integrated Approach*. London: Routledge.

Cook, J. M., Biyanova, T., Elhai, J., Schnurr, P. P., & Coyne, J. C. (2010). What Do Psychotherapists Really Do In Practice? An Internet Study of Over 2,000 Practitioners. *Psychotherapy Theory, Research, Practice, Training*, 47(2), 260-267.

Cooper, M. & McLeod, J. (2011). *Pluralistic counselling and Psychotherapy*. London: Sage.

Department of Health (2001). *Treatment choices in psychological therapies and counselling*. London: Department of Health. In Cooper, M. & McLeod, J. (2011). *Pluralistic counselling and Psychotherapy*. London: Sage.

Dovidio, J. F. & Gaertner, S. L. (2006). A multilevel perspective on prejudice: Crossing disciplinary boundaries. In P. A. M. Van Lange (Ed.), *Bridging social psychology: Benefits of transdisciplinary approaches* (pp. 385-390). Mahwah: Lawrence Erlbaum. In Larsson, B. P. M., Broberg, A. G. & Kaldo, V. (2013). Do psychotherapists with different theoretical orientations stereotype or prejudge each other? *Journal of Contemporary Psychotherapy*, 43, 169-178.

Erskine, R. G., Moursund, J. P. & Trautman, R. L. (1999) *Beyond Empathy: A Therapy of Contact-in-Relationship*. New York: Brunner-Routledge.

Erskine, R. G. & Trautman, R. L. (1996) Methods of an Integrative Psychotherapy. *Transactional Analysis Journal*, 26(4): 316-28

Festinger, Leon (1957). *A theory of cognitive dissonance*. Evanston, IL: Row, Peterson

Goulding, M. M. & Goulding, R. L. (1979) *Changing Lives Through Redecision Therapy*. New York: Grove Press

Garfield, S. L. & Kurtz, R. (1977). A study of eclectic views. *Journal of Clinical and Consulting Psychology*, 45, 78-83. In Norcross, J. C. (2005). A Primer on Psychotherapy Integration. In J. C. Norcross & M. R. Goldfried (Eds.), *Handbook of psychotherapy integration* (pp. 3-23). New York: Oxford University Press.

Harford, D. (2013). Preliminary evaluation of Outcomes of Transactional Analysis Psychotherapy for Armed Forces Veterans Presenting with Post-traumatic Stress Disorder. *International Journal of Transactional Analysis Research*, 4(3)

Hargaden, H. & Sills, C. (2002). *Transactional Analysis: A Relational Perspective*. Hove: Brunner-Routledge.

Hollanders, H. (2003). The eclectic and integrative approach. In R. Woolfe, W. Dryden, & S. Strawbridge (Eds.), *Handbook of Counselling Psychology*. London: Sage. In Cooper, M. & McLeod, J. (2011). *Pluralistic counselling and Psychotherapy*. London: Sage.

Hollanders, H., & McLeod, J. (1999). Theoretical orientation and reported practice: A survey of eclecticism among counsellors in Britain. *British Journal of Guidance & Counselling*, 27 (3), 405-414.

Klein, M. (1988). *Envy and Gratitude and Other Works 1946 – 1963*. London: Virago. In Howard, S. (2006). *Psychodynamic Counselling in a Nutshell*. London: Sage.

Larson, D. (1980). Therapeutic schools, styles and schoolism: A national survey. *Journal of Humanistic Psychology*, 20, 3-20. In Norcross, J. C. (2005). A Primer on Psychotherapy Integration. In J. C. Norcross & M. R. Goldfried (Eds.), *Handbook of psychotherapy integration* (pp. 3-23). New York: Oxford University Press.

- Larsson, B. P. M., Broberg, A. G. & Kaldo, V. (2013). Do psychotherapists with different theoretical orientations stereotype or prejudge each other? *Journal of Contemporary Psychotherapy*, 43, 169-178
- McLeod, J. (2009). *An Introduction to Counselling*(4<sup>th</sup> Edition). Maidenhead: Open University Press.
- Moiso, C. & Novellino, M. (2000). An overview of the psychodynamic school of transactional analysis. *Transactional Analysis Journal*,30(3), 182-187.
- Norcross, J. C. (2005). A Primer on Psychotherapy Integration. In J. C. Norcross & M. R. Goldfried (Eds.), *Handbook of psychotherapy integration* (pp. 3-23). New York: Oxford University Press
- Norcross, J. C., Karpiak, C. P., & Lister, K. M. (2005). What's an integrationist? A study of self-identified integrative and (occasionally) eclectic psychologists. *Journal of Clinical Psychology*, 61 (12), 1587-1594
- Novellino, M. & Moiso, C. (1990). The psychodynamic approach to transactional analysis. *Transactional Analysis Journal*,20,(3) 187-192.
- Operatio, D. & Fiske, T. (2001). Stereotypes: Content, structures, processes and content. In R. Brown & S. L. Gaertner (Eds.), *Intergroup processes*. Malden MA: Blackwell Publishers. In Larsson, B. P. M., Broberg, A. G. & Kaldo, V. (2013). Do psychotherapists with different theoretical orientations stereotype or prejudge each other? *Journal of Contemporary Psychotherapy*, 43, 169-178.
- Orlinsky, D., Ronnestad, M.H., Gerin, P., Willutski, U., Dazord, A., Ambuhl, H., Davis, J., Davis, M., Botermans, J-F. & Cierpka, M. (1999). Development of Psychotherapists: Concepts, Questions, and Methods of a Collaborative International Study. *Psychotherapy Research*, 9(2), 127-153.
- Schiff, J & Contributors. (1975) *The Cathexis Reader: Transactional Analysis Treatment of Psychosis*. New York: Harper & Row.
- Schlegel, L. (1998) What is Transactional Analysis? *Transactional Analysis Journal*, 28(4): 269-87
- Schore, A. (1994). *Affect regulation and the origin of the self: The neurobiology of emotional development*. Hillsdale, NJ: Erlbaum. In Rolfe, W. (2000). Rethinking Feelings: Integrating the Biology of Emotion with Redecision Therapy. *Journal of Redecision Therapy*, 2 (1), 13-31.
- Stark, M. (2000) *Modes of Therapeutic Action*. Northvale: Jason Aronson.
- Stern, D. (1985). *The interpersonal world of the infant*. Basic Books: New York.
- Stewart, I. (1996) *Developing Transactional Analysis Counselling*. London: Sage.
- Stewart, I. (2000) *Transactional Analysis Counselling in Action*. London: Sage.
- Tajfel, H. & Turner, J. C. (1979). An Integrative Theory of Intergroup Conflict. In W. G. Austin & S. Worchel (Eds.), *The Social Psychology of Intergroup Relations*. Monterey, CA: Brooks-Cole .
- Widdowson, M. (2013). *The process and outcome of transactional analysis psychotherapy for the treatment of depression: an adjudicated case series*. Unpublished doctoral thesis. University of Leicester.